

# ROAD STANDARDS MANUAL

## BONNER COUNTY, IDAHO



Photo Courtesy of District 3 Crew

MARCH 2019 VERSION 2.1



### **BONNER COUNTY ROAD & BRIDGE**

1500 Hwy 2 Suite 101 • Sandpoint, ID 83864 • Phone: (208) 255-5681  
Fax: (208) 263-9084 E-mail: [roads@bonnercountyid.gov](mailto:roads@bonnercountyid.gov)

PAGE INTENTIONALLY BLANK

## **PURPOSE AND AUTHORITY**

It is the purpose of this manual to provide consistent standards for construction and maintenance of new and existing roads and appurtenant structures built within Bonner County public right-of-ways and for those portions of approaches and driveways which enter upon County roads, within rights of ways owned by Bonner County or onto roads maintained by Bonner County but not within dedicated rights of way, and for construction and maintenance of utilities within rights of way owned by Bonner County or onto roads maintained by Bonner County but not within dedicated rights of way.

PAGE INTENTIONALLY BLANK

# ROAD STANDARDS MANUAL BONNER COUNTY, IDAHO

<b>CONTENTS</b>	<b>PAGE NO.</b>
SECTION 1: GENERAL PROVISIONS AND REQUIREMENTS	3
SECTION 2: UTILITY CONSTRUCTION PERMITS & STANDARDS	7
SECTION 3: COMMERCIAL & ROAD APPROACH PERMITS AND STANDARDS	15
Plate 1: Standard Approaches	21
Plate 2: Sight Triangle at Intersections	22
SECTION 4: RESIDENTIAL DRIVEWAY PERMITS AND STANDARDS	23
Plate 3: Standard Driveways	28
SECTION 5: STREET NAME AND NEW ROAD SIGNS	29
SECTION 6: STANDARDS FOR NEW PUBLIC ROAD CONSTRUCTION FOR DEDICATION TO BONNER COUNTY	31
Plate 4: Standard Cul de Sac Layout	38
Plate 5: Typical Road Cross Section	39
Plate 6: Typical Curb and Gutter Construction	40
Plate 7: Typical Culvert Installation	41
SECTION 7: STANDARDS FOR CONSTRUCTION AND MAINTENANCE OF PRIVATELY MAINTAINED PUBLIC ROADS	55
Plate 8: Typical Road Cross Section – Private Maintenance	59
SECTION 8: STANDARDS FOR NEWSPAPER AND MAILBOXES	65
SECTION 9: BONNER COUNTY TRAFFIC IMPACT STUDY GUIDELINES	67
Traffic Impact Study Checklist	73
SECTION 10: GENERAL MAINTENANCE PROCEDURES	74
APPENDICES	
APPENDIX A: ADOPTING ORDINANCE & RESOLUTION	86
APPENDIX B: FEE SCHEDULE	88

PAGE INTENTIONALLY BLANK

## SECTION 1: GENERAL PROVISIONS AND REQUIREMENTS

### DEFINITIONS

Applicant. The person(s), corporation, utility, etc that is requesting approval of a permit from Bonner County.

Approach. As used in this manual, the term "approach" shall mean any vehicular entrance upon a County right-of-way, other than a "driveway".

Bonner County Road and Bridge Department. As used in this manual, the term "Bonner County Road and Bridge Department" shall mean Bonner County Road & Bridge Department.

Control Zone Areas. Spaces alongside the travelway which are used for the road shoulder, ditch, stormwater conveyance, snow storage, vehicle recovery, etc. These spaces should be kept clear of obstructions in the interest of safety to allow a vehicle which has left the travelway an opportunity to recover or stop safely without impacting obstructions.

County. The term "County" refers in all instances to Bonner County, Idaho.

County Right-of-Way or right-of-way. As used in this manual, the term "County right-of-way" or "right-of-way" shall mean any road right-of-way owned by Bonner County or proposed for dedication to Bonner County or roads maintained by Bonner County but not within dedicated rights of way, or those right-of-ways dedicated to the public but not maintained by the County.

Director. As used in this manual, the term "Director" shall mean the Director of Bonner County Road & Bridge Department, or designated representative.

Encroachment – Any object, structure, and/or facility not naturally occurring which is placed in the right-of-way by parties other than Bonner County, or any work performed in the right-of-way which does not qualify as typical maintenance of existing facilities, or any non-typical use of the right-of-way for special events.

Engineer. As used in this manual, the term "Engineer" shall mean a licensed professional engineer employed by the Bonner County Road and Bridge Department.

Driveway. As used in this manual, the term "driveway" shall mean a vehicular entrance upon a County right-of-way or a County maintained roadway which provides access to a duplex or two or fewer single-family residences. Once there are three or more single-family residences, it shall be required to be a road "approach" and be named and meet the standards of Section 3 of this manual.

Grantee. Also see "Applicant." The person, corporation, or utility receiving permits, permissions, or other entitlements from Bonner County (the Grantor).

New road. As used in this manual, the term "new road" shall mean any road built for dedication as a public road within the Bonner County Road System. It shall not be deemed to include existing public roads within the Bonner County Highway System, nor road construction or reconstruction undertaken by Bonner County.

Permits. Official documents issued by Bonner County which authorize an applicant to perform the specified work in the specified manner.

Project engineer. As used in this manual, the term "project engineer" shall mean a Registered Professional Engineer, licensed in the State of Idaho and who is retained to design, construct or supervise the construction of a new road.

Road surface, roadway. As used in this manual, the terms "road surface" and "roadway" shall mean the travelway and the road shoulders on each side.

Slope. The angle of incline expressed as a percentage which is derived by dividing the measured height from base to top, by the horizontal distance from base to top.

Travelway That portion of a County right-of-way which has been improved for the movement of vehicles, exclusive of shoulders.

## **1.1 APPLICABILITY**

The standards contained within this manual shall be applicable to:

1. The construction of all new roads and appurtenant structures proposed and built for dedication to Bonner County, and all roads to be entered into the County's maintenance system;
2. The construction and maintenance of all utility facilities located within rights of way owned by Bonner County or within 25 feet of centerline of roads maintained by Bonner County, but not within dedicated rights of way;
3. The construction of all new approaches and driveways entering upon County maintained roads or located within rights of way owned by Bonner County, and existing approaches and driveways entering upon County maintained roads or located within rights of way owned by Bonner County where property improvements or land planning actions require Bonner County Road and Bridge Department approval;
4. The erection or placement of all new road and traffic control signs, mailboxes, and appurtenant structures within rights of way owned by Bonner County or within 25 feet of centerline of roads maintained by Bonner County.



5. Nothing in this manual shall be construed to require that Bonner County undertake to reconstruct, widen or improve an existing County road within the Bonner County road system to the standards and specification contained in or adopted in this manual.
6. Nothing in this manual shall be construed to require that those portions of new or existing private roads, approaches or driveway outside of the rights of way owned or maintained by Bonner County, be constructed, reconstructed, widened or improved to the standards and specifications contained in or adopted by this manual.
7. Nothing in this manual shall be construed to obligate Bonner County to accept the dedication of any road or right of way, regardless of the standards and specifications used for the construction of such road.

## **1.2 CLASSIFICATION OF ROADS**

For the purpose of administration of the standards contained within this manual, all new roads shall be classified as Arterials, Collectors or Local Access Roads. The classification of new roads shall be consistent with the following guidelines:

1. Arterials Main transportation routes serving a system of Collector and Local Access Roads, which connect to the State Highway System or serve as an important travel corridor.
2. Collectors Secondary transportation routes serving a system of Local Access Roads, and connecting to other Collectors or to Arterials. Collectors are classified as Major Collectors or Minor Collectors based on their traffic counts.
3. Local Access Roads. Transportation routes primarily providing access to adjacent land, and connecting to Collectors or Arterials.

Upon completion, dedication, acceptance and opening, new roads shall be shown, according to their classification on the "Bonner County Road Classification Map".

## **1.3 TYPES OF LOCAL ACCESS ROADS**

For the purposes of the standards contained in this manual, the category "Local Access Roads" is further divided into three subcategories as shown below. Where the term "Local Access Road" is used within the text, it shall include all of the following subcategories:

- A. High Density Local Road. A Local Access Road, in any area zoned for lot or parcel sizes of twelve thousand (12,000) square feet or less in size on the official Bonner County Zoning Map.
- B. Standard Local Road. A Local Access Road with a projected traffic volume\* of two hundred (200) or more Vehicle Trips per Day, or in an area zoned for lot or parcel sizes greater than twelve thousand (12,000) square feet and less than five (5) acres in size on the official Bonner County Zoning Map.
- C. Low Volume Local Road. A Local Access Road with a projected traffic volume\* of less than two hundred (200) Vehicle Trips per Day, and in an area

zoned for lot or parcel sizes of five (5) acres or greater on the official Bonner County Zoning Map. Local Road 'C' will not be maintained by Bonner County.

\* Projected traffic volumes to be based on 10 Vehicle Trips per Day per Household over the design life of the road (usually 20 years).

## SECTION 2: UTILITY CONSTRUCTION PERMITS AND STANDARDS

### 2.1 APPLICABILITY

A. Prior to the start of construction of public or private utility projects within County rights-of-way, the applicant or utility shall obtain a permit for such use from the Bonner County Road and Bridge Department and in accord with Title 2 BCRC. The permit shall be applied for and granted in the name of the utility, not an individual, unless the utility is owned by an individual and the utility does not collect fees. The fee for a Utility Construction Permit is set by Resolution of the Bonner County Board of Commissioners. Permit fees and cut fees will be waived for taxing utility districts and government agencies.

B. This standard hereby adopts ISPWC (Idaho Standards for Public Works Construction) trenching standards (Division 300), water standards (Division 400), sewer standards (Division 500), and culverts standards (Division 600) in their entirety as well as all requirements and instructions on the Bonner County Utilities Construction Permit.

C. A Utilities permit is required whenever any trenching/boring or pole/pedestal placement is necessary within County right-of-way or onto roads maintained by Bonner County which are not within dedicated rights-of-way, even if a permit has been granted for previous work in the same location. The approved permit must be on-site any time work is proceeding. Other work such as brushing that requires traffic control (signs, flaggers etc) requires notifying the Bonner County Road and Bridge Department 48 hours prior to commencing work. In the event of an emergency, the permittee must immediately notify Bonner Dispatch at 265-5525 and Bonner County Road and Bridge Department at 255-5681.

D. Any work which is done prior to obtaining a permit shall incur an investigative fee of \$65 in addition to the permit fee.

E. All utilities shall be installed in accordance with local, state, and federal rules and regulations, and the Applicant shall contact other agencies for the required inspections and approvals. It is not the responsibility of Bonner County to inspect or enforce applicable rules and regulations of other local, state, and federal agencies.

### 2.2 GENERAL

A. Not all County maintained roads exist within a County-owned right-of-way, some are prescriptive only. The County, by issuance of this permit, makes no

representation as to existence, location or width of right-of-way. It is the Grantees responsibility to determine these items. Though a permit is required on all rights-of-way and publicly maintained roads (deeded or prescriptive), the Grantee is responsible to notify any affected property owners and obtain whatever private easements are necessary. If there is a question whether the work is within the public right-of-way, the utility shall provide evidence to the Bonner County Road and Bridge Department to verify the work is occurring on private property.

B. Utility installations shall be located to minimize the need for later adjustment, to accommodate future roadway improvements and to provide service access to such installation with minimum interference to roadway traffic. Utility companies shall make specific inquiries as to long-range county road improvement plans in order to minimize both utility customer and road user inconvenience should further road improvements (on existing or new alignment) require adjustment or relocating of the utility. The County reserves the right to require the Grantee to change the location or to remove any structures, lines or pipes authorized by this permit at any time in order for the County to perform any needed work on or in the right-of-way, said change or removal to be made at the sole expense of the Grantee or their successors or assigns.

C. If the Grantee does not complete the work to the County's satisfaction, the County may fix the deficiencies and bill the Grantee. The County reserves the right to refuse the issuance of a permit if previous projects initiated by the Applicant or their designated contractor have not been completed to the County's satisfaction or required conditions have not been met.

D. It is the applicant's responsibility to contact "One-Call" prior to the start of construction by dialing "811."

### **2.3 PERFORMANCE GUARANTEE & CUT FEES**

A. A Performance Guarantee shall be required for the installation of utilities for franchised power and natural gas distribution systems, telecommunications systems; and water, waste water, and storm drainage systems at the following rates:

1. \$10.00 per foot greater than 10 feet from the shoulder of the road.  
\$25.00 per foot for a gravel road within 10 feet of the shoulder of the road.  
\$35.00 per foot for a hard surface road within 10 feet of the shoulder of the road; or
2. 150% of the Director's estimate of the cost to repair the roadway; or

3. A utility or licensed public works contractor may post cash or a performance bond with Bonner County in the amount of \$50,000 per year.

B. Performance guarantees shall be in the form of a performance bond from a licensed bonding agency, or a cashiers check which will be cashed by the Bonner County Treasurers Department and held in an account until the required time period has elapsed, at which point the money may be refunded.

C. The performance Guarantee shall be held for two (2) years after acceptance of the project by the Bonner County Road and Bridge Department.

D. The Director reserves the right to specify the required bonding type. The Director may elect to waive the requirement for a performance guarantee if the work is being performed by a reputable utility with a long standing history of good working relations with Bonner County.

E. For utility installations on a privately maintained public right-of-way, the Director may opt not to require a performance guarantee if the risk to the public use of the road being impacted is minimal.

F. Cut Fees shall be charged in addition to the permit fee whenever the applicant intends to cut through a hard surfaced road which has received a surface treatment (asphalt, BST, or chip seal) within the last 7 years. These cut fees will be pro-rated based on the length of time since the most recent treatment, and can be found on the Road and Bridge Dept Fee Schedule A which is attached at the back of this manual.

1. Cut fees will not apply to taxing utility districts or government agencies.
2. Cut fees are not refunded at the end of the performance guarantee window.
3. Such cuts will only be allowed when other non-intrusive measures such as boring are impractical or impossible in the opinion of the Road and Bridge Department.

## **2.4 DESIGN DRAWINGS**

A. Prior to the start of construction, the applicant or utility shall submit design drawings showing the location of any poles, lines, piping, culverts or any structure or facility located or to be located within the County right-of-way. Work shall not begin until the design drawings have been approved in writing and they comply with BCRC Title 2. The drawings shall indicate these locations with respect to the road surface, shoulders and ditches, the right-of-way line, bridges, culverts, drainage structures, driveways, road intersections and any other road improvement structure within the right-of-way. The drawings must be approved by the Bonner County Road and Bridge Department before a permit is issued. The drawings shall at a minimum contain the following:

1. Project name and number
2. North Arrow
3. Scale
4. Distance of installation from shoulder of road (minimum 10' unless specifically approved due to site characteristics)
5. Distance of installation from right-of-way (maximum of 5' unless specifically approved due to site characteristics)
6. Depth of installation (from bottom of ditch)
7. Section drawings of any road crossings or joint trenches (road crossings shall be approximately 90 degrees)
8. Compaction requirements (in accordance with latest edition of ISPWC)
9. Location of all valves, hydrants, services, pedestals, poles, etc.
10. Above ground markings and locator tape or wire
11. Traffic control plan or signs

B. As-built drawings showing accurate locations of all elements of the project are to be submitted to the Bonner County Road and Bridge Department within 45 days of completion of the project and will be maintained in the road files.

C. All construction shall proceed in compliance with the standards set forth in this section, the latest edition of the ISPWC, the terms of the construction permit and the approved design drawings submitted.

## **2.5 STANDARDS FOR UNDERGROUND UTILITY PLACEMENT AND CONSTRUCTION**

A. Utility lines may be installed under the road surface using techniques which do not require a cut through the road surface, such as tunneling, burrowing or driven pipe. It is County policy that unless site characteristics prohibit, all utility crossings on roads with a hard surface shall be accomplished in a manner that will not disturb the surfacing. Exception may be made by the Director for the existing surface quality of the road or if it appears no other options are feasible. Repairs to the hard surfacing shall be made at the direction of the Director and shall be at the expense of the grantee. The fee for open cuts of a hard surfaced road is set by Resolution of the Board of Bonner County Commissioners. This fee is in addition to the Utilities Construction Permit fee and can be found on the Road and Bridge Dept Fee Schedule A which is attached at the back of this manual.

B. This standard hereby adopts ISPWC standards (Division 300, 400, 500, and 600) in its entirety. If any discrepancy exists, this standard (Title 2, BCRC) shall govern.

C. Testing is required in accordance with ISPWC. It shall be the responsibility of the applicant to provide certified density test reports. Test results shall be submitted to the Bonner County Road and Bridge Department. Testing for the

installation of communication and power lines by "plowing" shall be at the determination of the Bonner County Road and Bridge Department.

D. Utility line crossings of a road should be as near a right angle (normal) to the road centerline as practicable.

E. Longitudinal installation should be located as near as practicable to the right-of-way line and on uniform line and grade. With exception to utility line crossings, no utilities shall be installed under the roadway.

F. Spoils shall be cast away from the roadway whenever practicable. The roadway must be swept or otherwise cleaned at the end of each working day. All trenches left open at the end of the day shall have barricades in accordance with the latest edition of the MUTCD (Manual on Uniform Traffic Control Devices). A maximum of 10 feet of open trench will be allowed at the end of the working day.

G. If, in the determination of the Bonner County Road and Bridge Department or the project engineer weather conditions prohibit proper installation, work shall be stopped. During winter months when it may be impossible to adhere to these standards, Bonner County reserves the right not to issue permits for work until conditions improve.

H. When possible the Bonner County Road and Bridge Department recommends joint trenching by the utilities. The design shall follow the most stringent standards of the utilities in the joint trench as approved by the Bonner County Road and Bridge Department.

I. Where utility cables, water lines, and sewer lines cross a road or right-of-way, such cables and lines shall be encased in a conduit or secondary encasement extending two (2) feet beyond the ditch line or to the edge of any fill within the right-of-way. These conduits shall be made of materials suitable for the application which can withstand crushing and pressure when required, such as schedule 80+ PVC for electrical lines, C900 PVC or ductile iron for water lines, 3034 PVC or HDPE for gravity sewer lines, etc. Examples of materials which are not suitable include: schedule 40 PVC and corrugated steel pipe (culvert). If the carrier pipe is too large to make secondary encasement practical, a ductile iron carrier pipe without secondary encasement may be allowed by the Engineer (i.e. an 18"+ ductile iron water transmission main, as an example).

J. All underground utility installations must include tracer wire placed along the pipe.

## **2.6 TESTING**

A. Consistent with the above and prior to placing any surface materials on the roadway, it shall be the responsibility of the Grantee to provide certified density test reports to the Bonner County Road and Bridge Department.

B. A minimum of one test shall be taken within every 200 feet of trench length and at depths of 50 percent of trench depth and at the surface, or as specified by the Bonner County Road and Bridge Department. Compaction of laterals or service line trenches shall be tested where required by the Bonner County Road and Bridge Department.

## **2.7 ABOVE GROUND UTILITIES**

A. Power poles and other above ground utility objects should be placed outside of Control Zone Areas (see definitions) unless justified to the Bonner County Road and Bridge Department's satisfaction by suitable engineering studies considering traffic safety, or where shielded by a barrier, placed in an area normally inaccessible to vehicles or utilize a breakaway design to the greatest extent possible. Installation of power poles and other above ground utility objects will not be permitted in sidewalks, or pedestrian/bicycle pathways.

B. Location of poles shall be compatible with driveways, intersections and other roadway features (i.e., they shall not interfere with sight distance, roadway signing, traffic signals, culverts etc.) Where possible, utilities shall share facilities so that a minimum number of poles are needed.

C. Whenever practicable, relocation of poles or obstacles shall be made away from the existing roadway. Costs of relocating poles or obstacles to achieve these Standards are the responsibility of the developer whose project necessitates compliance with these Standards. This is not intended to prevent the developer from making financial arrangements with an appropriate utility or other owner of the obstacle to accomplish removal of the pole or obstacle.

## **2.8 RESTORATION REQUIREMENTS**

A. Existing drainage ditches, culverts, etc., shall be kept clean at all times and temporary diversion of any drainage system will not be permitted without the consent of the Bonner County Road and Bridge Department. Any drainage culvert, catch basin, manhole or other drainage structures disturbed by excavation shall be replaced with new material or repaired to the satisfaction of the Bonner County Road and Bridge Department. Temporary erosion/sedimentation control measures shall be employed to protect adjacent property and storm drain facilities in accordance with Best Management Practices.



B. Any disturbance of the travel surface, shoulders, ditches drainage or traffic control devices shall be repaired and restored to its prior condition or to a reasonable extent as determined by Bonner County Road and Bridge Department in order to protect the integrity of the roadway. If trenches or pavement settling should occur within two (2) years of the installation of the utility, repairs shall be made by the applicant or utility as directed by the Bonner County Road and Bridge Department and at no cost to the County. If the applicant or utility fails to make the necessary repairs, the County may initiate the repair and bill the applicant or utility or the County may use the performance guarantee or a portion thereof to make the necessary repairs. No new construction permits within County rights-of-way will be issued to the applicant or utility until such claim has been settled.

C. Upon completion of construction of the lines and facilities, all rubbish and debris shall be immediately removed and the roadway and the roadside shall be left neat and presentable to the satisfaction of the County.

D. All areas within the County right-of-way which have been disturbed or denuded of vegetation shall be reseeded in accordance to ISPWC standards as soon as possible after utility construction is completed to the satisfaction of the Bonner County Road and Bridge Department.

## **2.9 PUBLIC SAFETY**

A. No construction work shall be started on utility placement until the Bonner County Road and Bridge Department has given notice to the applicant or utility to proceed. The Bonner County Sheriff's Office shall be notified by the applicant or utility of the date(s) and time(s) of full or partial road closures associated with the utility placement to allow for any rerouting of emergency vehicles that may be necessary. The applicant or utility shall publish a notice of any full road closures in a locally distributed newspaper at least two (2) weeks in advance of the closure, stating the date and location of the closure, and the estimated duration of the closure. The applicant or utility shall also post signs on the road where a full closure is to occur at least two (2) weeks prior to the closure notifying the traveling public of the dates, times and duration of the closures. Alternative forms of public notification may be considered on local access dead end roads. These alternatives shall be approved by the Bonner County Road and Bridge Department at least two (2) weeks prior to the closure.

B. If in the opinion of the Bonner County Road and Bridge Department weather conditions deteriorate to the point where the traveled roadways are unsafe for the public or detrimental to the restoration of the roadway, excavation shall cease immediately and cleanup shall be promptly accomplished.

C. During construction work, barricades, lights and other traffic control devices shall be erected and maintained as may be necessary to conform to the Manual

on Uniform Traffic Control Devices and in accordance with the approved traffic control plan.

D. Equipment parking and materials storage shall be as far from the road surface as feasible in a location approved by the Bonner County Road and Bridge Department. Equipment or materials left overnight within thirty (30) feet of the road surface shall be marked and/ or protected, so as not to constitute a hazard to the traveling public. This section shall not be construed to authorize trespassing upon private lands adjacent to County roads or rights-of-way for the purpose of construction, equipment parking or materials storage.

## **SECTION 3: COMMERCIAL & ROAD APPROACH ENCROACHMENT PERMITS AND STANDARDS**

### **3.1 APPLICABILITY**

A. Prior to the start of any construction activity of that portion of an approach located within a County right-of-way, the property owner or his agent shall make application for an approach permit to the Bonner County Road and Bridge Department on forms provided by the Department in accord with Title 2, BCRC. Applications shall be accompanied by a drawing showing the design and location of the approach and any culverts, traffic control devices or other structures associated with the approach construction. A vicinity map shall accompany the application showing the location of the County right-of-way, and the travel way for a distance of four hundred (400) feet in each direction from the new access. Other intersections, approaches and driveways shall be shown upon the vicinity map. The fee for an approach permit is set by Resolution of the Bonner County Board of Commissioners.

B. This standard hereby adopts all requirements and instructions on the approach permit.

C. It is the applicant's responsibility to contact "One-Call" prior to the start of construction by dialing "811."

D. For the purposes of this Section, the term "approach" shall be used to mean all entrances and intersections for three or more residences (a road) or any commercial or industrial access including temporary or permanent logging roads. An entrance for less than three residences is included in Section 4, Driveway Permits and Standards.

E. The standards within this section shall be applicable to that portion of new entrances located within a County right-of-way, or entering upon a County maintained road.

F. Any changes in the type of surfacing or use shall require a permit. Maintenance of existing surface type, including lifts of new gravel up to 3" thick, may not require a permit unless the Bonner County Road and Bridge Department feels that the maintenance activities will detrimentally impact the roadway.

G. Any work which is done prior to obtaining a permit shall incur an investigative fee of \$65 in addition to the permit fee.

### **3.2 GENERAL**

A. Access to State Highways is regulated by the Idaho Transportation Department (ITD). The property owner is responsible to coordinate with ITD for satisfactory completion of any requirements.

B. Access to Bonner County roads & public right-of-ways is regulated..

1. Corner lots may be required to access on the roadway with the lowest classification and as close as practicable to the property line most distant from the intersection.

2. All new intersections shall comply with Section 6.7 and 6.11 of this standard.

3. All construction of accesses shall conform with the standards within this Section and with the terms of the permit issued.

4. Accesses shall be designed so that backing maneuvers from or onto a public road shall not be required for access.

5. In new subdivisions, the developer may be required to provide joint access to lots with frontage of less than 300 feet.

C. A traffic impact study may be required for subdivisions, multi family residences, commercial or industrial accesses. The costs of the study shall be the responsibility of the applicant. Refer to Section 9, Bonner County Traffic Impact Study Guidelines.

D. The Bonner County Road and Bridge Department has the right to review the safety issues of all accesses onto the public roadway and require a new permit for previously constructed accesses which pose a risk to the public. The permit fee in these cases may be waived by the Director if there are no other triggers requiring the new encroachment permit such as a Building Location Permit in progress. Under the new permit, work may be required to satisfy the critical safety criteria such as, but not limited to, sight distance, sight triangle, or a slope which prevents vehicles from sliding into the roadway during adverse conditions or water flowing out onto the roadway which may freeze and create a hazard. If an owner refuses to file for a new permit and do the required safety work, Road and Bridge may perform the required work at the owners expense.

### **3.3 STANDARDS**

That portion of any new access within a County right-of-way or entering onto county maintained roadways shall comply with the following standards:

A. The location, design and configuration of the access shall conform to the specifications and dimensions shown on Plate 1.

B. Wherever possible, no new access on collectors or arterial roads shall be located within three hundred and thirty (330) feet of an existing access, or the intersection of two public road rights-of-way. Locate accesses directly across from existing accesses where possible.

C. New accesses shall intersect the roadway at an angle of between eighty (80) and ninety (90) degrees, and as close to ninety (90) degrees as is possible.

D. Culverts under new accesses and located within a County right-of-way shall have a minimum diameter of twelve (12) inches and shall be double walled HDPE pipe or galvanized metal. Culverts shall be located and sized so as to form a continuation of the existing roadside drainage system and shall extend beyond the toe of any fill placed in association with the access. An engineering study may be required to size the culvert at the discretion of the Bonner County Road and Bridge Department, the cost of the study shall be at the expense of the applicant. The Bonner County Road and Bridge Department also has the ability to require galvanized metal in certain circumstances.

E. That portion of approaches located within a County right-of-way shall have a minimum travel surface width of thirty (30) feet and a maximum width of 50ft unless otherwise approved by the Road and Bridge Dept, and the surface of the access shall be connected to the surface of the County roadway by a curve with a radius of at least thirty (30) feet on both sides. Note: Where a full 30 foot radius quarter-arc (as shown on Plate 1) cannot be fit between the edge of the travelway and the edge of the right-of-way, a 30 foot radius shall still be used, starting tangent to the edge of the approach at the right-of-way line and extending until it intersects the edge of the travelway.

Where curbs and gutters have been installed or are planned to be installed, the driveway shall be constructed a minimum of 30ft wide with wings to maintain the integrity of the curb and gutter.

F. Maximum effort shall be made to ensure all new approaches slope downward from the roadway. The approach shall be designed as to prevent surface water runoff from reaching the County roadway. That portion of a new approach located within a County right-of-way shall have a maximum slope of six percent plus or minus (6%+/-) and a minimum slope of 2%+/-.

G. The minimum sight distance for new approaches entering arterial, collector or local access roads shall be a minimum of:

**Table 1: Commercial & Road Approach Sight Distance Requirements**

MPH	25	35	45	55
Asphalt Road (Flat)	155 FT	250 FT	360 FT	495 FT
Asphalt Road (6% Downgrade)	165 FT	271 FT	400 FT	553 FT
Gravel Road (Flat)	186 FT	300 FT	432 FT	594 FT
Gravel Road (6% Downgrade)	198 FT	325 FT	480 FT	663 FT

\*Sight distances in above table are based on the AASHTO "[Policy on Geometric Design of Highways and Streets](#)" Exhibit 3-1 and Exhibit 3-2 for comfortable stopping sight distances on wet asphalt. Gravel road stopping distances have been increased by 20% of their asphalt

counterparts. If the characteristics of the road near the approach prohibit travel at the posted speed limit, such as in narrow areas with tight curves, the Road and Bridge Department Engineer may use engineering judgement to select a more reasonable speed from the table to be used at the approach, but shall not be less than 25mph. For slopes other than the 6% downgrade listed, the Engineer may interpolate data to determine the required sight distance.

With a minimum sight triangle of 40 feet. See Plate 2, Sight Triangle at Intersections. Permittee/Owners shall be required to perform necessary brush removal and/or excavation to maintain sight distance.

If the design speed is not posted in the field a design speed of 35 MPH will be assumed for encroachment permits on gravel roads and 45 MPH will be assumed for encroachment permits on paved roads, unless determined otherwise by the Road and Bridge Engineer.

The Applicant may challenge the sight distance requirements by hiring a licensed professional engineer to complete a sight stopping distance & safety study for the proposed location and make recommendations to Bonner County Road and Bridge Department's Engineer and/or Director, who may accept or reject the recommendations for decreased sight distance requirements.

H. During construction of approaches, such barricades, signs, and other traffic control devices shall be erected and maintained in conformance with the latest edition of the Manual on Uniform Traffic Control Devices and in accordance with the approved traffic control plan.

I. The surface materials for approaches shall be a crushed rock such as ¾" minus, 1" minus, or 2" minus or a hard surface such as asphalt or concrete. If using a hard surface approach on a gravel road, the hard surfacing shall not extend closer than 5ft to the edge of the travelway to avoid being caught by snow plows or interfering with other maintenance operations.

### **3.3.1 TEMPORARY ACCESS STANDARDS**

A. An Applicant may apply for a temporary access encroachment permit in cases when the access will be used for no more than 6 months, such as during logging operations. The requirements for a temporary access shall be identical to those of a permanent approach except for the items listed below:

1. The required width of a temporary access shall be 20 feet instead of 30 feet. 30 ft radii will still be required to facilitate the tracking of large vehicles.
2. The required slope downward from the roadway may be a maximum of 10% instead of 4%. On sites where a downward slope is infeasible, an upward slope of up to 6% may be allowed at the discretion of the Road and Bridge Department when weather is above freezing for the duration of

- operations. Drainage must be designed to keep water from running onto the road.
3. The angle of intersection with the road shall be between 60° and 90° instead of 80° to 90°.
  4. Culverts may still be required by the Road and Bridge Department.
- B. Upon completion of operations, the access must be removed and the ditchline and right-of-way restored as per Section 3.4 below. The applicant shall contact the Road and Bridge Dept to notify that the restoration has been completed.

### **3.4 RESTORATION REQUIREMENTS**

A. During construction, the roadway and ditches shall be kept clean of mud, dirt, and other debris. If necessary, the Applicant shall sweep or wash the roadway as needed throughout construction. The construction of a temporary rock construction entrance may also be required if at any time the Road Department feels it necessary to ensure a clean roadway. Rock construction entrances shall be no closer than 5ft to the edge of the travelway to avoid large rocks being kicked into the travelway.

B. Existing drainage ditches, culverts, etc., shall be kept clean at all times and temporary diversion of any drainage system will not be permitted without the consent of the Bonner County Road and Bridge Department. Any drainage culvert, catch basin, manhole or other drainage structures disturbed by excavation shall be replaced with new material or repaired to the satisfaction of the Bonner County Road and Bridge Department. Temporary erosion/sedimentation control measures shall be employed to protect adjacent property and storm drain facilities in accordance with Best Management Practices.

B. Any disturbance of the travel surface, shoulders, ditches drainage or traffic control devices shall be repaired and restored to its prior condition or better. If surface or pavement settling should occur within one (1) year of the installation of the approach, repairs shall be made by the applicant as directed by the Bonner County Road and Bridge Department and at no cost to the County. If the applicant fails to make the necessary repairs, the County may initiate the repair and bill the applicant. No new permits within County rights-of-way will be issued to the applicant until such claim has been settled.

C. Upon completion of construction of the approach, all rubbish and debris shall be immediately removed and the roadway and the roadside shall be left neat and presentable to the satisfaction of the County.

D. All areas within the County right-of-way which have been disturbed or denuded of vegetation shall be reseeded, in accordance to ISPWC standards,

as soon as possible after construction is completed to the satisfaction of the Bonner County Road and Bridge Department.

E. Maintenance of the approach and any culverts under the approach shall be the sole responsibility of the Applicant and their successors.



# PLATE 1: STANDARD APPROACHES

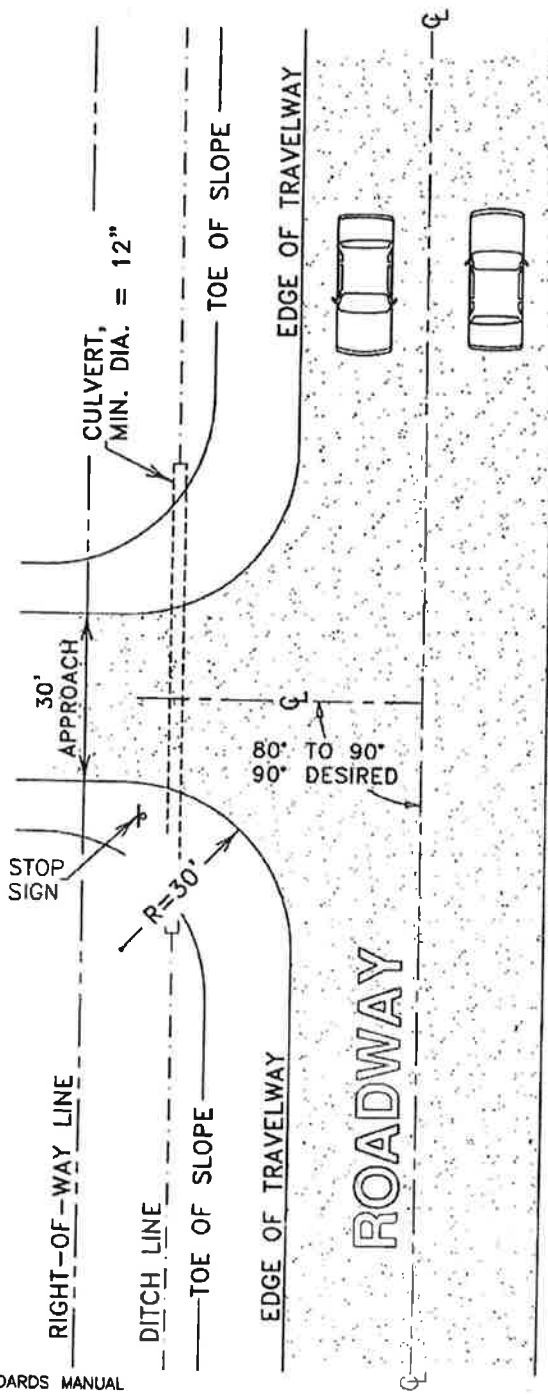

## PLAN DIMENSION REQUIREMENTS

NOT TO SCALE

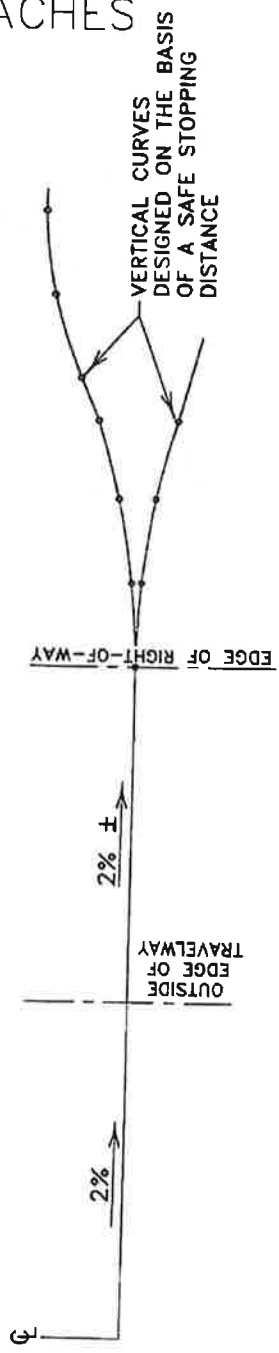

## GRADE REQUIREMENTS

NOT TO SCALE

# PLATE 2: SIGHT TRIANGLE AT INTERSECTIONS

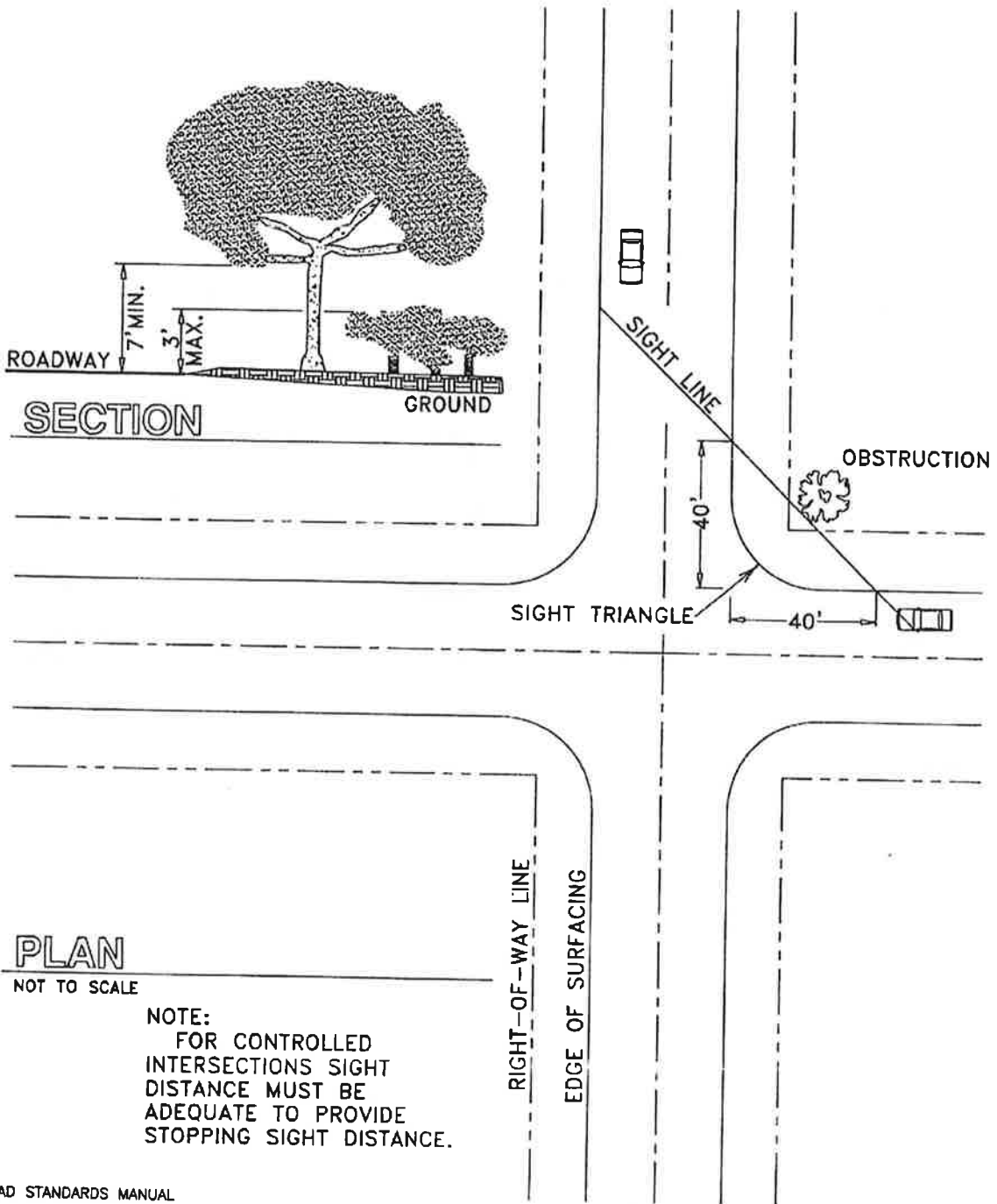

## **SECTION 4: RESIDENTIAL DRIVEWAY PERMITS AND STANDARDS**

### **4.1 APPLICABILITY**

A. Prior to the start of construction of that portion of any new driveway providing access to a maximum of two (2) single family residences or a duplex dwelling or building site within a County right-of-way or public road right-of-way, the property owner or his agent shall make application for a driveway permit to the Bonner County Road and Bridge Department on forms provided by the Department. Applications shall be accompanied by a drawing showing the design and location of the access and any culverts, traffic control devices or other structures associated with the access construction. A vicinity map shall accompany the application showing the location of the County right-of-way, and the travel way for a distance of four hundred (400) feet in each direction from the new access. Other intersections, approaches and driveways shall be shown upon the vicinity map. The fee for an access permit is set by Resolution of the Bonner County Board of Commissioners.

B. This standard hereby adopts all requirements and instructions on the permit.

C. It is the applicant's responsibility to contact "One-Call" prior to the start of construction by dialing "811."

D. For the purposes of this Section, the term "driveway" shall mean a vehicular entrance upon a County right-of-way or a County maintained roadway which provides access to a duplex or two or fewer single-family residences.

E. The standards within this section shall be applicable to that portion of new driveway entrances located within a County right-of-way, or entering upon a County maintained road.

F. Any changes in the type of driveway surfacing or use shall require a permit. Maintenance of existing surface type, including lifts of new gravel up to 3" thick, may not require a permit unless the Bonner County Road and Bridge Department feels that the maintenance activities will detrimentally impact the roadway.

G. Any work which is done prior to obtaining a permit shall incur an investigative fee of \$65 in addition to the permit fee.

### **4.2 GENERAL**

A. Access to State Highways is regulated by the Idaho Transportation Department (ITD). The property owner is responsible to coordinate with ITD for satisfactory completion of any requirements.

B. Bonner County reserves the right to restrict access onto County roads. In new subdivisions, the developer may be required to provide joint driveways to lots with frontage of less than 300 feet. Corner lots will be required to access on the roadway with the lowest classification and as close as practicable to the property line most distant from the intersection. All construction of driveways shall conform with the standards within this Section and with the terms of the permit issued. The Bonner County Road and Bridge Department has the right to review the safety issue of all driveways onto the public roadway and require a new permit for previously constructed driveways.

C. Driveways should be designed so that backing maneuvers from or onto an arterial or collector road will not occur.

D. The Bonner County Road and Bridge Department has the right to review the safety issues of all accesses onto the public roadway and require a new permit at any time for un-permitted previously constructed accesses which pose a safety risk to the traveling public. The permit fee may be waived by the Director if there are no other triggers requiring the new encroachment permit such as a Building Location Permit. Under the new permit, work may be required to satisfy the critical safety criteria such as, but not limited to, sight distance, sight triangle, or a slope which prevents vehicles from sliding into the roadway during adverse conditions. If an owner refuses to file for a new permit and do the required safety work, Road and Bridge may perform the required work at the owners expense.

### **4.3 STANDARDS**

That portion of any new driveway within a County right-of-way shall comply with the following standards:

A. The location, design and configuration of the driveway shall conform to the specifications and dimensions shown on Plate 3, Standard Driveway.

B. New driveways shall intersect the roadway at an angle of between eighty (80) and ninety (90) degrees, and as close to ninety (90) degrees as is possible. The 10° allowance may be to either side of 90°. The Engineer or Director may allow exceptions when steep slopes along the road prohibit a perpendicular connection. In these cases, a flat pad parallel to the road may be considered as an alternative to allow cars a safe place to come to a stop during winter conditions before they enter the roadway. In no cases shall a steep sloping driveway enter directly onto the road.

C. Culverts under new driveways and located within a County right-of-way shall have a minimum diameter of twelve (12) inches and shall be double walled

HDPE pipe or galvanized metal. Culverts shall be located and sized so as to form a continuation of the existing roadside drainage system and shall extend beyond the toe of any fill placed in association with the access. An engineering study may be required to size the culvert at the discretion of the Bonner County Road and Bridge Department, the cost of the study shall be at the expense of the applicant. The Bonner County Road and Bridge Department also has the ability to require galvanized metal in certain circumstances.

D. The minimum sight distance for new driveways entering arterial, collector or local access roads shall be a minimum of:

**Table 2: Residential Driveway Sight Distance Requirements**

MPH	25	35	45	55
Feet	150	225	325	450

If the characteristics of the road near the approach prohibit travel at the posted speed limit, such as in narrow areas with tight curves, the Road and Bridge Department Engineer may use engineering judgement to select a more reasonable speed from the table to be used at the approach, but shall not be less than 25mph.

A minimum sight triangle with side lengths of 40 feet shall be maintained. See Plate 2, Sight Triangle at Intersections. Permittee/Owners shall be required to perform necessary brush removal and/or excavation to maintain sight distance.

If the design speed is not posted in the field a design speed of 35 MPH will be assumed for encroachment permits on gravel roads and 45 MPH will be assumed for encroachment permits on paved roads, unless determined otherwise by the Road and Bridge Engineer.

E. During construction of driveways and when equipment operates in a County roadway, barricades, signs, and other traffic control devices shall be erected and maintained in conformance with the Manual on Uniform Traffic Control Devices and in accordance with an approved traffic control plan.

F. New driveways shall have a minimum travel surface width of twenty (20) feet within the County right-of-way and a maximum width of 40ft unless otherwise approved by the Road and Bridge Dept, and the surface of the driveway shall be connected to the surface of the County road way by a curve with a radius of at least twenty (20) feet on both sides. The location, design and configuration of the driveway shall conform to the relevant specifications and dimensions shown on Plate 3, Standard Driveway. Note: Where a full 20 foot radius quarter-arc (as shown on Plate 3) cannot be fit between the edge of the travelway and the edge of the right-of-way, a 20 foot radius shall still be used, starting tangent to the edge of the approach at the right-of-way line and extending until it intersects the edge of the travelway.

Where curbs and gutters have been installed or are planned to be installed, the driveway shall be constructed a minimum of 20ft wide with wings to maintain the integrity of the curb and gutter design.

G. Reasonable effort shall be made to ensure all new approaches slope downward from the roadway. That portion of a new driveway located within a County right-of-way shall have a maximum slope of six percent plus or minus (6% +/-) and a minimum slope of 2%+/- . The driveway shall be designed as to prevent surface water runoff from reaching the County roadway.

H. The surface materials for approaches shall be a crushed rock such as ¾" minus, 1" minus, or 2" minus or a hard surface such as asphalt or concrete. If using a hard surface approach on a gravel road, the hard surfacing shall not extend closer than 5ft to the edge of the travelway to avoid being caught by snow plows or interfering with other maintenance operations.

#### **4.4 RESTORATION REQUIREMENTS**

A. During construction, the roadway and ditches shall be kept clean of mud, dirt, and other debris. If necessary, the Applicant shall sweep or wash the roadway as needed throughout construction. The construction of a temporary rock construction entrance may also be required if at any time the Road Department feels it necessary to ensure a clean roadway. Rock construction entrances shall be no closer than 5ft to the edge of the travelway to avoid large rocks being kicked into the travelway.

B. Existing drainage ditches, culverts, etc., shall be kept clean at all times and temporary diversion of any drainage system will not be permitted without the consent of the Bonner County Road and Bridge Department. Any drainage culvert, catch basin, manhole or other drainage structures disturbed by excavation shall be replaced with new material or repaired to the satisfaction of the Bonner County Road and Bridge Department. Temporary erosion/sedimentation control measures shall be employed to protect adjacent property and storm drain facilities in accordance with Best Management Practices.

C. Any disturbance of the travel surface, shoulders, ditches drainage or traffic control devices shall be repaired and restored to its prior condition or better. If surface or pavement settling should occur within one (1) year of the installation of the driveway, repairs shall be made by the applicant as directed by the Bonner County Road and Bridge Department and at no cost to the County. If the applicant fails to make the necessary repairs, the County may initiate the repair and bill the applicant. No new permits within County rights-of-way will be issued to the applicant until such claim has been settled.

D. Upon completion of construction of the driveway, all rubbish and debris shall

be immediately removed and the roadway and the roadside shall be left neat and presentable to the satisfaction of the County.

E. All areas within the County right-of-way which have been disturbed or denuded of vegetation shall be reseeded, in accordance to ISPWC standards, as soon as possible after construction is completed to the satisfaction of the Bonner County Road and Bridge Department.

F. Maintenance of the approach and any culverts under the approach shall be the sole responsibility of the Applicant and their successors.

# PLATE 3: STANDARD DRIVEWAY

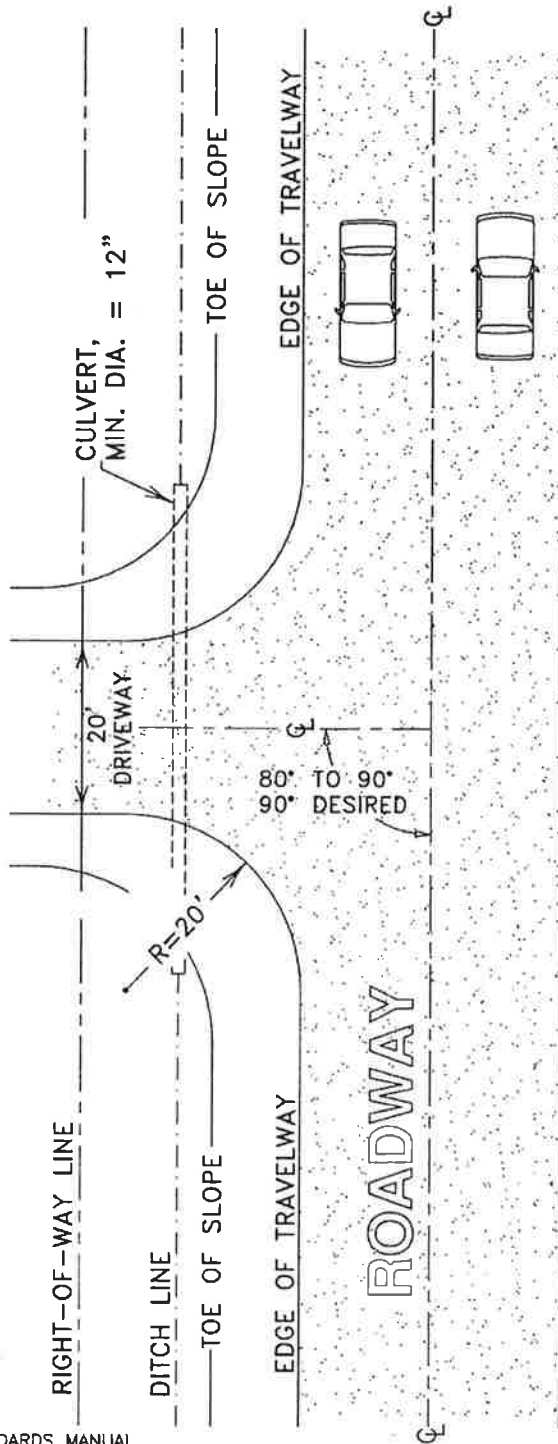

## PLAN DIMENSION REQUIREMENTS

NOT TO SCALE

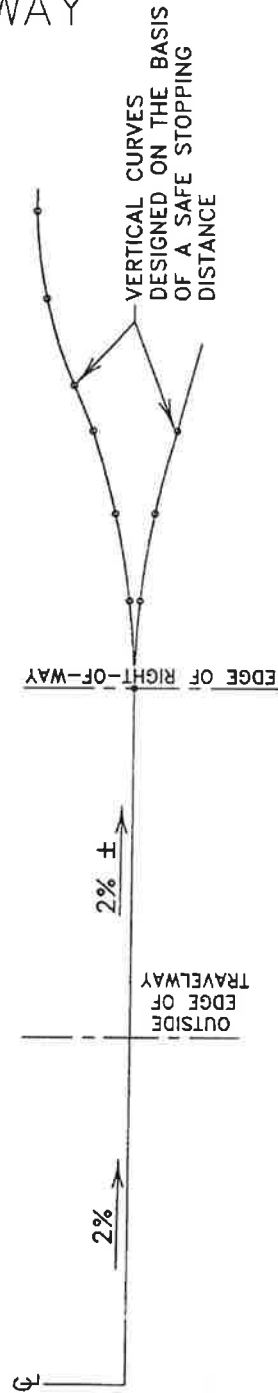

## GRADE REQUIREMENTS

NOT TO SCALE



## **SECTION 5: STREET NAME AND NEW ROAD SIGNS**

### **5.1 APPLICABILITY**

All road signs, street name signs and traffic control or warning signs located within County rights-of-way shall conform to the standards set forth in this section.

### **5.2 STANDARDS**

All permanent signing shall be shown on the plans for a new road. All new, permanent road signs and temporary signs during construction shall conform to the standards contained in the latest edition of the Manual on Uniform Traffic Control Devices.

### **5.3 INSTALLATION AND ACCEPTANCE**

Prior to the installation of any permanent road sign within a County right-of-way, by any person or entity other than the Bonner County Road and Bridge Department, plans for the sign shall be submitted to the Bonner County Road and Bridge Department. The plans shall be examined for conformance with the standards within this Section, and shall approve or disapprove the sign design based on those standards.

### **5.4 CONVERSION OF EXISTING SIGNS**

Whenever an existing road sign, located within a County right-of-way, is damaged or destroyed to the extent of more than fifty percent (50%) of its replacement value, the sign shall be reconstructed in compliance with the standards for new road signs by the responsible entity.

### **5.5 PROHIBITION OF OTHER SIGNS**

No signs other than those erected for the purposes of road information, motorist information, traffic control, notice or warning signs shall be placed in the County right-of-way, unless a variance from these standards has been granted by the Board of County Commissioners.

### **5.6 RESPONSIBLE PARTY**

Road name signs on privately maintained roads will not be erected and maintained by Bonner County. It shall be the responsibility of the developer to purchase, erect and maintain the road name signs for public roads, privately

maintained. It shall be the responsibility of the developer to purchase and erect the initial road name signs for public roads, publicly maintained.

### **5.7 ROAD NAMES**

The naming of roads shall be governed by Title 2 Chapter 7, NAMING OF ROADS AND ROAD SIGNS

## **SECTION 6: STANDARDS FOR NEW PUBLIC ROAD CONSTRUCTION FOR DEDICATION TO BONNER COUNTY**

### **6.1 GENERAL REQUIREMENTS**

Construction of new roads built for dedication to Bonner County or existing roads proposed for dedication shall conform to the standards set forth in this Section. As a part of the decision to permit roads and construction encroachments within the County rights of way the Road and Bridge Department may enter into development agreements with the encroachment applicant that may require the completion of improvements to mitigate the increase in traffic as a result of the project development or encroachment. Alternately, the Road and Bridge Department may allow an applicant to participate proportionately with other applicants and /or other public entities to construct improvements that are not exclusively the responsibility of any single applicant or entity. Development agreements shall be approved by the Bonner County Board of Commissioners by resolution.

All Arterial and Collector roads designed and constructed by the Idaho Transportation Department with the intent of having Bonner County maintain them shall be designed and constructed as "all weather roads". Bonner County reserves the right to approve the design of all roads that shall be maintained by the County.

### **6.2 BONDING FOR ROADS**

A. Upon completion of construction, a performance bond in the amount of 100% of construction costs shall be in place for one year, for all paved roads prior to acceptance by Bonner County.

B. Additional bonding on roads will be necessary if a section of the road is tested less than 92% Rice Density, the performance bond shall be extended for one (1) additional year; Rice Density of less than 90% will be rejected and need to be repaved.

### **6.3 DESIGN & LAYOUT**

A. The Idaho Standards for Public Works Construction (ISPWC), the most recent edition, and the most recent edition of the Policy on Geometric Design of Highways and Streets published by the American Association of State Highway

and Transportation Officials (AASHTO) shall serve as guides for project engineers in the design of all new roads.

B. New roads shall be laid out and designed to conform with the current Bonner County Transportation Plan and in accordance with the transportation portion of the Comprehensive Plan.

C. New roads serving residential subdivisions shall be designed to connect to Local Access Roads or Collectors. New roads shall be designed to provide access to each lot, in such a manner as to eliminate the need for residential driveways entering onto existing Arterial and Collector Roads and to minimize the access onto the existing roads.

#### **6.4 SPECIFICATIONS FOR DRAWINGS**

A. The project engineer shall prepare road and right-of-way drawings, and each sheet of the drawings shall bear the seal of said engineer. A licensed surveyor may prepare the right-of-way drawings, and each sheet of the drawings shall bear the seal of said surveyor.

B. Two (2) copies of the design drawings shall be submitted to the Bonner County Road and Bridge Department for review. All drawings shall include the following when applicable:

1. The first sheet of the plans shall include a project title, vicinity map, and index of plan sheets.
2. Road alignments with 50' stationing, reading from left to right, and stationing at point of curve, tangent, and intersections, with appropriate ties to existing road surveys and stationing, section corners, quarter corners, and the horizontal control established by the engineer. Stations shall increase from west to east and from south to north.
3. Section, township and range.
4. Bearings on the road centerline, keyed to an associated plat map.
5. Curve data including radius, delta, arc length, and semi-tangent length, on all road centerlines and curb returns.
6. Right-of-way lines, width for proposed road, intersecting roads, and existing road improvements with dimensions.
7. All topographic features within right-of-way limits or future right-of-way limits and sufficient area beyond to resolve questions of setback, slope, drainage, access onto abutting property, and road continuations.
8. All existing utilities.
9. All proposed water and sewer utilities that will be designed and constructed.
10. Identification of all roads and adjoining subdivisions.
11. A Traffic Control Signing Plan and Striping Plan.

12. Existing and proposed drainage features, showing direction of flow, size and kind of each drainage channel, pipe, and structure and other specified requirements in any county storm water management specifications.
13. Horizontal Scale: 1" = 50' and a Vertical Scale of 1" = 10'. However, 1" = 100' shall be optional for development of lots one acre or larger. Details for clarification may be shown on a convenient scale. A scale of 1" = 20' may be required for urban arterial streets where detail is sufficiently dense to cause a "cluttered" drawing at a smaller scale.
14. A north arrow.
15. Project beginning and ending designation with stations.
16. A title block to include:
  - a. The project name
  - b. County Project Number
  - c. Sheet number
  - d. Road names
  - e. Road limits
18. All found and referenced survey monuments.
19. Section and lot lines.
20. Beginning, middle, and ending elevations of curb returns.
21. Other data necessary for the specific project.
22. Project construction detouring and traffic control requirements.
23. All Appurtenant Structures.

### **6.5 WIDTH OF RIGHT-OF-WAY REQUIRED \***

A. New roads shall have a minimum right-of-way based on the classification of the road as follows:

<b>Classification of road</b>	<b>Minimum Right-of-way</b>	<b>Roadway Width</b>	<b>Travelway Width</b>	<b>Asphalt Surface</b>
Arterial	80 to 100 feet	34 feet	24 feet	yes
Collector	60 to 80 feet	34 feet	24 feet	yes
Local Access Roads	60 feet			
A. High Density Local Road		40 feet	24 feet	yes
B. Standard Local Road		28 feet	22 feet	yes
C. Low Volume Local Road		26 feet	22 feet**	no

\*All new road rights-of-way shall be of sufficient width to accommodate all cuts or fills. Where extreme cut or fill sections cannot be contained within the minimum right-of-way, additional right-of-way width will be required.

\*\* Greater, if required by the local Fire District. Local Access Roads C not maintained by Bonner County.

B. Cul de sac design shall conform to the specifications shown on Plate 4, Cul de sac Layout.

C. Effort shall be made to provide through streets within a subdivision and minimize the need for dead ends. Cul de sacs shall have a right-of-way sufficient to provide area within the right-of-way for storage of snow removed from the roadway.

D. Cul de sacs shall have a minimum sixty (60) foot right-of-way radius. The actual right-of-way shall be of sufficient additional radius length as may be necessary to accommodate all cuts and fills within the right-of-way and to provide sufficient area within the right-of-way for storage of snow removed from the cul de sac.

## **6.6 ROAD DESIGN**

The Typical rural road section shall be designed in accordance with Plate 5, Typical Road Cross Section. The minimum and maximum for design parameters of new roads shall be:

<b>DESIGN PARAMETER</b>	<b>ARTERIAL</b>	<b>COLLECTOR</b>	<b>LOCAL ACCESS ROAD</b>
Vertical grades	Min. 0.5% Max. 6%	Min. 0.5% Max. 6%	Min. 0.5%, Max. 8%* Max for cul de sac 2%
Horizontal curvature on centerline	Min. radius of 830 ft.	Min. radius of 510 ft.	Min. radius of 150 ft.
Design speed	45-55 mph	35-45 mph	25-35 mph
Super elevation	Max. of 0.06 ft./ ft. Min. of 0.02 ft/ft	Max. of 0.06 ft./ ft. Min. of 0.02 ft/ft	Max of 0.06 ft./ ft. Min. of 0.02 ft/ft
Minimum run out length	150 ft.	120 ft.	110 ft.

\*8% allowed with no more than 200 feet in length, 100 feet between grade sections with a break. No horizontal curves allowed within 100 feet of the 8% grade.

## **6.7 ROAD INTERSECTIONS**

A. All new roads which intersect existing public roads and rights-of-way shall intersect at an angle which is between eighty (80) and ninety (90) degrees, and as close to ninety (90) degrees as is possible. The edge of the road surfaces shall be connected with a curve having a minimum radius of thirty (30) feet, as depicted in Plate 1, Standard Approaches. The road surface in cul de sac bulbs shall be connected with the road surface providing access to it with a curve having a minimum radius of thirty-five (35) feet, as depicted in Plate 4, Standard Cul de sac Layout.

B. The road approach area is used for vehicle storage while waiting to enter an intersection, and shall be designed with a nearly flat grade. For public roads publicly maintained or public roads privately maintained, the road approach area at a stop controlled intersection (e.g. stop sign, yield sign, or traffic signal) shall have a downgrade approaching the intersection of no greater than 2%. An upgrade approaching the intersection shall be no steeper than 4%. The minimum length of the road approach area, measured from the edge of curb face, or traveled way where curbs are not present, is to be in accordance with the Table below. For any road classification not listed in the Table, the Road and Bridge Director may require a traffic analysis to determine the road approach length.

Average Daily Traffic (ADT)	Minimum Road Approach Length (2% Maximum Down Grade and 4% Maximum Upgrade)	
	Local Access Streets	Collector/Arterials
ADT < 200	25 Feet	50 Feet
200 < ADT < 400	50 Feet	75 Feet
400 < ADT < 1000	75 Feet	100 Feet
1000 < ADT	75 Feet	Analysis required

## **6.8 CURB AND GUTTER DESIGN**

Where curbs and gutters are planned or required, the parameters illustrated in Plate 6, Typical Curb and Gutter Construction, shall serve as a design guide.

## **6.9 DRAINAGE ALONG/ ACROSS ROADS**

A. Ditchlines are intended to be designed, constructed and used as a conveyance system for stormwater which originates on the roadway surface. They are not intended, nor shall they be used for the retention and infiltration of stormwater. It shall not be the responsibility of the roadside ditch to serve as a drain for private property on new or existing roads.

B. Culverts across new roads shall be a minimum of eighteen (18) inches in diameter, and shall be sized to carry the flow of the watercourse calculated with the discharge anticipated from a fifty (50) year design storm. Culverts shall extend beyond the toe of any fill. Culvert installation shall substantially conform to the specifications shown on Plate 7, Typical Culvert Installation, and the ISPWC manual specifications.

### **6.10 STOPPING AND PASSING SIGHT DISTANCES**

The minimum stopping and passing sight distances for new roads shall be:

**Table 3: Stopping and Passing Sight Distance Requirements**

Design Speed (MPH)	25	35	45	55
Stopping Sight Distance (Feet)	155	250	360	495
Minimum Required Sight Distance to Start a Passing Zone (Feet)	940	1040	1458	1918
Minimum Sight Distance Remaining to End Passing Zone (MUTCD Table 3B-1) (Feet)	450	550	700	900
K* Value for Sag Vertical Curve	26	49	79	115
K* Value for Crest Vertical Curve	12	29	61	114

\*K value is a coefficient by the algebraic difference in grade may be multiplied to determine the length in feet of the vertical curve which will provide the minimum sight distance. K is calculated as follows:  $L/A=K$ , where L is the horizontal distance in feet and A is the algebraic difference between the intersection of tangent grades divided by the length of the curve in feet equals A/L in percent per foot. The reciprocal is the distance in feet required to affect a one percent (1%) change in gradient, commonly called K.

(The following values are assumed for sight distance design: A. Driver's eye height: 3.50 ft. for computation of stopping sight distance. B. Object height: 4.25 ft. for computation of passing sight distance and 0.50 ft. for computation of stopping sight distance. C. Perception/ reaction time: assumed equal to 2.5 seconds for stopping sight distance.)

### **6.11 VISIBILITY AT INTERSECTIONS**

At intersections a minimum clear sight triangle shall be maintained as illustrated on Plate 2, Sight Triangle at Intersections.

### **6.12 APPURTENANT STRUCTURES**



This subsection shall apply to all roads and appurtenant structures, not just those along roads which are being newly constructed.

All retaining walls in excess of four (4) feet in height within the right-of-way shall be designed by a Professional Engineer Licensed in the State of Idaho.

A. Guardrails: Guardrail may be necessary in certain areas depending upon the warrants for protection of the traveling public. The Bonner County Road and Bridge Department reserves the right to determine the need for guardrail under each separate circumstance. The warrants for determining need of guardrail shall be made using the AASHTO Roadside Design Guide, latest edition.

The type of guardrail to be installed shall be determined by Bonner County Road and Bridge Department as location and maintenance coordination dictate.

B. Cattle guards: Cattle guards shall be constructed in conformance with the Manual for Highway & Street Standards prepared by the Local Highway Technical Assistance Council. Other types of cattle guards may be approved by the Bonner County Road and Bridge Department as appropriate from their individual experience. Maintenance of the cattle guards shall be at the expense of the property owner(s) whom the cattle guard benefits. If cattle guards become a hazard to the traveling public and property owners reject performing needed maintenance, Bonner County may remove the cattle guards or perform the needed repairs at the property owner's expense.

Idaho Code, Section 40-2310, regulates the installation of cattle guards on local highways and should be referenced when the question arises. It is encouraged to place them on private property, when necessary on private approaches.

Idaho Code, Section 40-203 (5), speaks to obstruction of the public right-of-way and the misdemeanor offense involved.

### **6.13 REVIEW FEES**

All required reviews and approvals by the Road and Bridge Director designee shall require the developer to pay a fee as set forth by Resolution of the Bonner County Board of Commissioners.

# PLATE 4: STANDARD CUL DE SAC LAYOUT

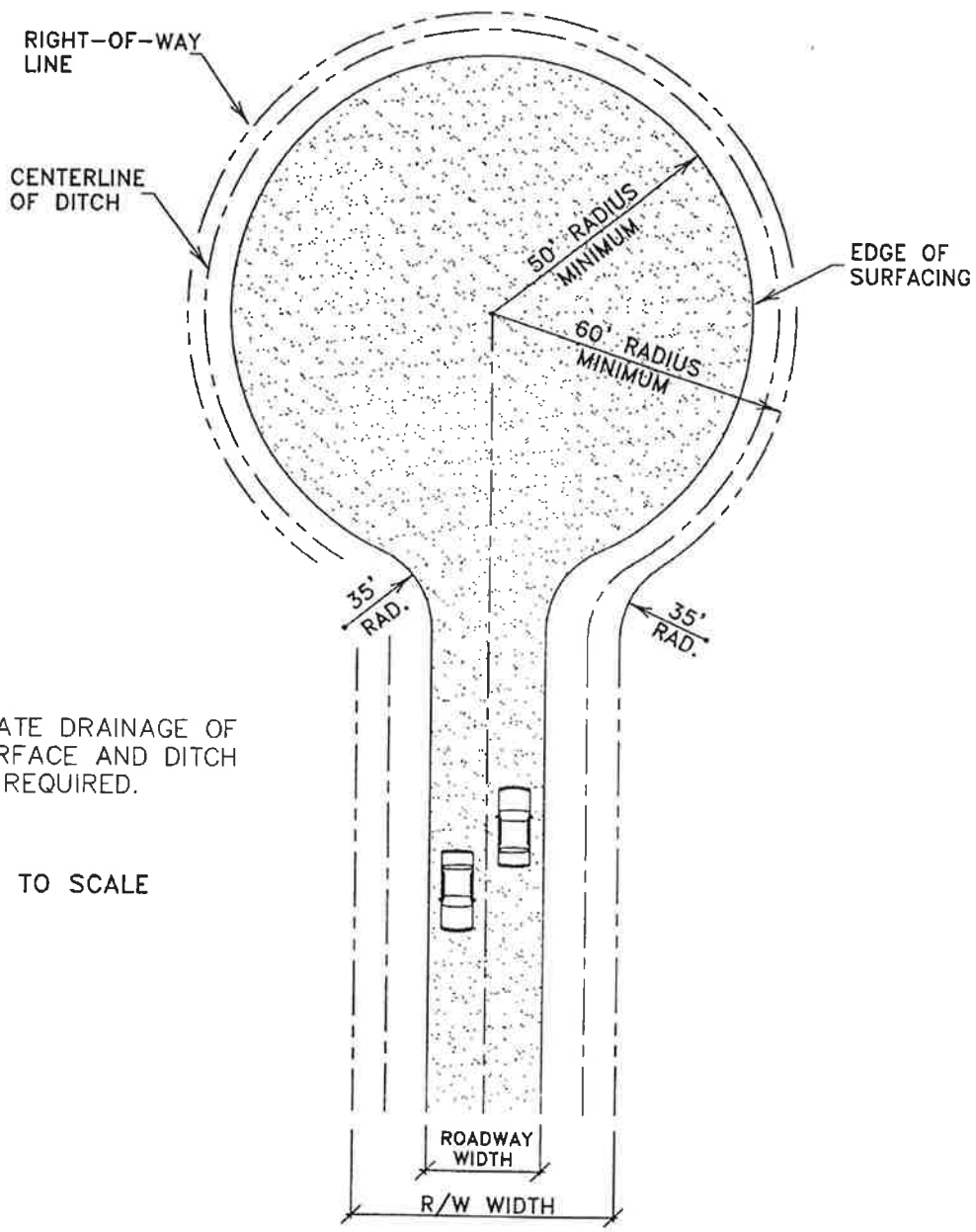

NOTE:  
ADEQUATE DRAINAGE OF  
THE SURFACE AND DITCH  
LINE IS REQUIRED.

NOT TO SCALE

# PLATE 5: TYPICAL ROAD CROSS SECTION

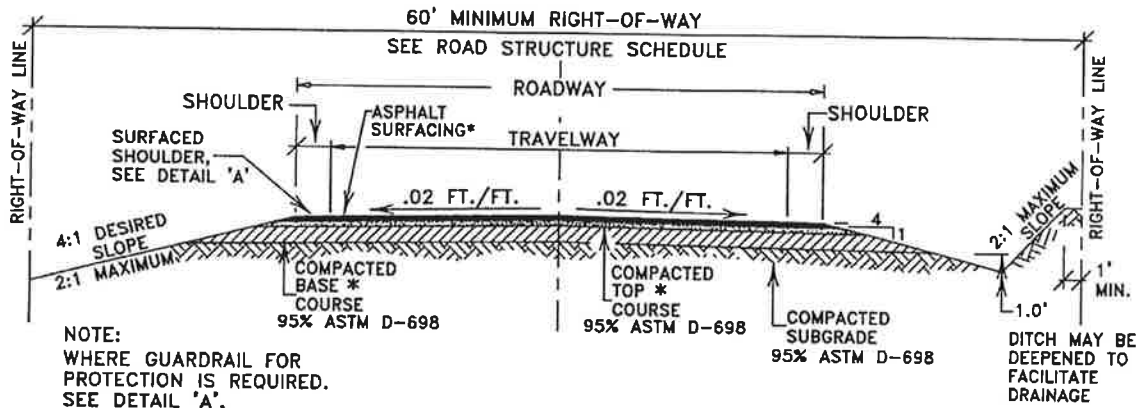

**TYPICAL RURAL ROAD SECTION**  
NOT TO SCALE

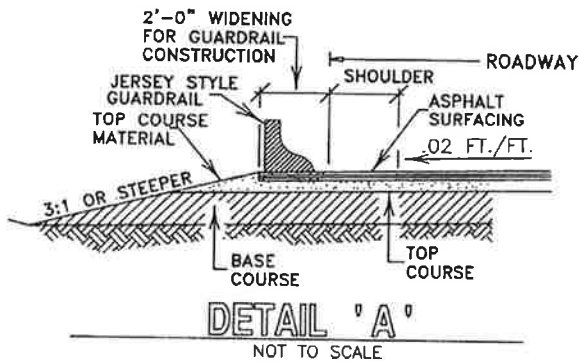

- NOTES:
- 1). AT A MINIMUM, RIGHT-OF-WAY SHALL BE CLEARED FROM TOE OF SLOPE TO TOP OF CUT.
  - 2). UTILITY CORRIDOR CLEARING MAY BE REQUIRED.
  - 3). GEOTEXTILE PRODUCTS MAY BE REQUIRED WITH CERTAIN SUBGRADES.
  - 4). EXPOSED SLOPES SHALL BE RESEEDD AS SOON AS POSSIBLE AFTER CONSTRUCTION COMPLETION.

LOCAL ACCESS ROADS  
 A = HIGH DENSITY LOCAL ROAD  
 B = STANDARD LOCAL ROAD  
 C = LOW VOLUME LOCAL ROAD

### ROAD STRUCTURE SCHEDULE \*

CLASS OF ROAD	TOP COURSE	BASE COURSE	TRAVELWAY WIDTH (FT.)	ROADWAY WIDTH (FT.)
ARTERIALS	6"	12"-18"	24'	34'
COLLECTOR	6"	12"-18"	24'	34'
LOCAL ACCESS ROADS				
LOCAL ROAD 'A'	4"	12"	24'	40'
LOCAL ROAD 'B'	4"	12"	22'	28'
LOCAL ROAD 'C'	4"	12"	22'	26'

\* SEE SECTION 7.6 FOR SURFACING REQUIREMENTS  
 LOCAL ROAD 'C' NOT MAINTAINED BY COUNTY

# PLATE 6: TYPICAL CURB AND GUTTER CONSTRUCTION WHERE REQUIRED

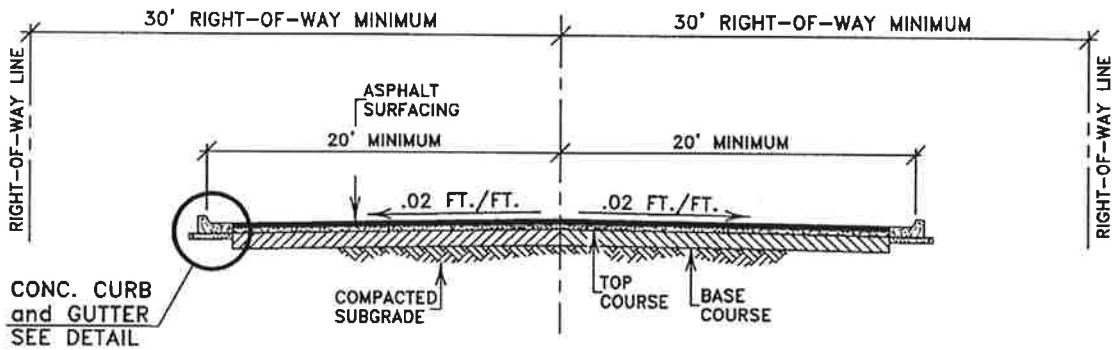

**TYPICAL HIGH DENSITY LOCAL ROAD SECTION**  
NOT TO SCALE

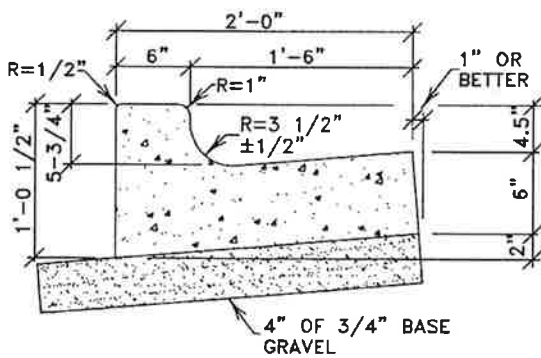

**VERTICAL CURB DETAIL**  
SCALE- N.T.S.

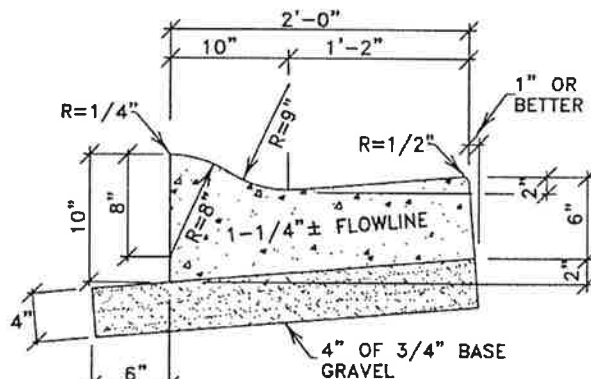

**ROLL CURB DETAIL**  
SCALE- N.T.S.

## PLATE 7: TYPICAL CULVERT INSTALLATION

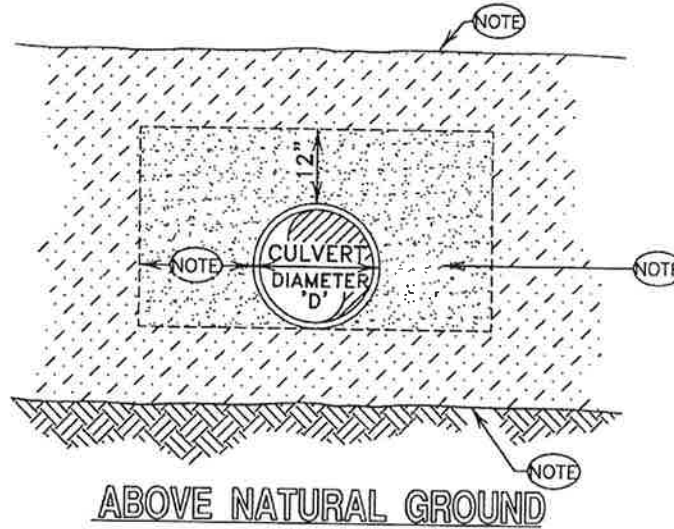

### NOTES FOR CULVERT INSTALLATION DETAILS

- (NOTE) CULVERT DIAMETER ('D') OR 12", WHICHEVER IS GREATER.
- (NOTE) FINISHED GRADE.
- (NOTE) MECHANICAL COMPACTED BACKFILL, PLACE IN 6" LAYERS.
- (NOTE) NATURAL GROUND.
- (NOTE) HAND TAMPED
- (NOTE) SHAPE TO FIT PIPE

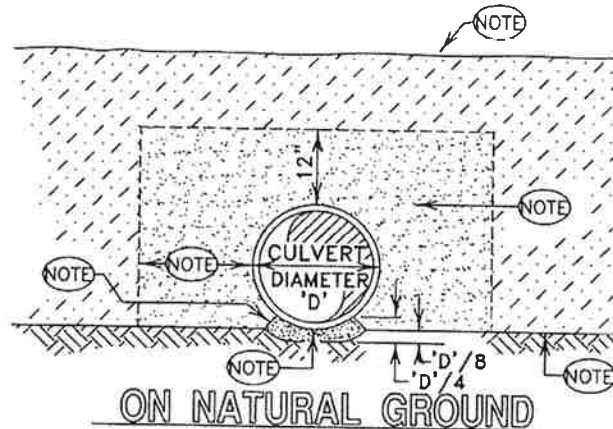
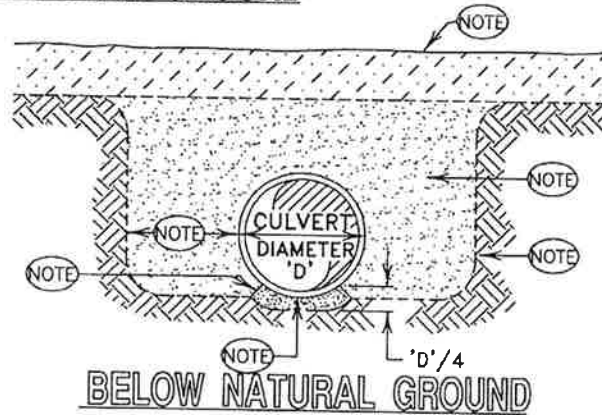

#### **6.14 CLEARING AND GRUBBING**

Prior to the start of road construction, clearing the entire width of the right-of-way on publicly maintained roads and grubbing within the roadway section on all public roads shall be completed. All materials removed by clearing or grubbing from the roadway shall be properly disposed of out of the right-of-way and in compliance with State and Local Permits. All denuded areas shall be hydro seeded at the end of the project or as specified in the Storm water and Erosion Control Plan.

#### **6.15 EROSION CONTROL**

During road construction, erosion control measures shall be installed and maintained to minimize soil erosion from disturbed sites. Permanent erosion control measures shall be included in all road designs, with design guidance from the Handbook of Best Management Practices for Stormwater Management and Erosion and the Idaho Standards for Public Works Construction. Refer to Chapter 24 of Title 12, of the Bonner County Revised Code for Stormwater Management and Erosion Control Plan requirements.

#### **6.16 SUBGRADE**

A. The sub grade shall consist of the natural materials remaining after all topsoil and duff (organic material) has been removed and good construction material is remaining. The extent of the excavation necessary to expose the sub grade shall be determined by the project engineer. Soil and compaction tests are required by the Bonner County Road and Bridge Department to document the acceptability for construction. All testing shall be at the expense of the developer.

B. In solid rock excavation, the solid rock shall be excavated 6 inches below the finished sub grade elevation and backfilled with approved granular material.

C. Unstable sub grade conditions shall be remedied by sub excavation and backfilling with approved material under the direction of the project engineer. Geo-synthetic materials may be required by the Road and Bridge Director, a designated representative, or the project engineer.

D. All construction shall be controlled by slope stakes or grade stakes as required, placed under the supervision of a Professional Engineer or Surveyor licensed in the State of Idaho.

E. Sub grade shall be compacted to a density no less than 95% of an ASTM D-698 Proctor Density.

F. Prior to placing any ballast on the sub grade, the Road and Bridge Director, Engineer, or designated representative shall have the opportunity to observe and approve the sub grade. **This is a requirement for all Public Roads.** The Director and/or the Engineer must have at least twenty-four (24) hours notice prior to the need for observation. Such 24 hours notice shall be given so that the observation can be made during the appropriate Bonner County Road and Bridge Department's normal working hours and work week. The Project Engineer is responsible for insuring that all testing, required inspections and standards outlined herein are adhered to.

G. Prior to requesting observation of the finished sub grade, grade stakes as required by the Project Engineer, set to finished sub grade elevation shall be in place on 50-foot stationing at centerline and shoulders.

**6.17 BALLAST**

A. All underground utilities or conduit crossing the road or in the road right-of-way to be installed before any ballast material.

B. Pit run material shall be used for the base course which has a sand equivalent of not less than thirty (30), and which meets the following graduations:

<u>Sieve Size</u>	<u>Percent Passing</u>
6 inch	100
3 inch	98 -- 100
2 inch	75 -- 100
1 inch	40 -- 80
#4	25 -- 60
#200	5 -- 12

The Director or Engineer may approve other materials to be used for ballast, such as 2.5" cap rock.

C. The ballast material shall be placed in loose eight inch (8") lifts and shall be compacted using mechanical methods to at least ninety-five percent (95%) of the ASTM D-698 Proctor Density.

D. Prior to placing any top course material on the ballast, the Road and Bridge Director, the Engineer, or designated representative shall have the opportunity to observe and approve the ballast. **This is a requirement for all Public Roads.** The Public Works Director or Engineer must have at least twenty-four (24) hours notice prior to the need for the observation. Such 24 hours notice shall be given so that the observation can be made during the appropriate Bonner County Road and Bridge Department normal working hours and work week.

E. Prior to requesting observation of the finished ballast, red top stakes set to finished ballast elevation, shall be placed at fifty foot (50') stationing on curves and one hundred foot (100') stationing on tangents at centerline and shoulders.

F. All culvert installations crossing the roadway shall be installed before any base material is placed and shall conform to Plate 7, Typical Culvert Installation.

**6.18 SOILS DESCRIPTIONS AND DEFINITIONS**

The following charts shall be used to assist in the soils classification and to determine the depth of the minimum required ballast and top course material.

<b>SOILS DESCRIPTIONS/DEFINITIONS</b>				
<b>MAJOR DIVISIONS</b>			<b>LETTER SYMBOL</b>	<b>TYPICAL DESCRIPTIONS</b>
<b>COARSE GRAINED SOILS</b>  More than 50% of material is than larger No. 200 sieve size	<b>GRAVEL AND GRAVELLY SOILS</b>  More than 50% of coarse fraction retained no. 4 sieve	<b>CLEAN GRAVELS</b> Little or no fines	<b>GW</b>	Well-graded gravels, gravel - sand mixtures, little or no fines
		<b>GRAVELS WITH FINES</b> Appreciable amount of fines	<b>GP</b>	Poorly - graded gravels, gravel - sand mixtures, little or no fines
			<b>GM</b>	Silty gravels, gravel - sand silt mixtures
		<b>SAND AND SANDY SOILS</b>  More than 50% of coarse fraction passing No. 4 sieve	<b>CLEAN SAND</b> Little or no fines	<b>GC</b>
	<b>SW</b>			Well - graded sands, gravelly sands, little or no fines
	<b>SANDS WITH FINES</b> Appreciable amount of fines	<b>CLEAN SAND</b> Little or no fines	<b>SP</b>	Poorly - graded sands, gravelly sands, little or no fines
			<b>SM</b>	Silty - sands, sand - silt mixtures
			<b>SC</b>	Clayey sands, sand - clay mixtures
			<b>FINE GRAINED SOILS</b>  More than 50% of material is smaller than No. 200 sieve size	<b>SILTS AND CLAYS</b>  Liquid limit less than 50
	<b>CL</b>	gravelly, clays, sandy clays, silty clays, lean clays		
<b>OL</b>	Organic silts and organic silty clays of low plasticity			
<b>SILTS AND CLAYS</b>  Liquid limit greater than 50	<b>MH</b>	Inorganic silts, micaceous or diatomaceous fine sand or silty soils		
	<b>CH</b>	Inorganic clays of high plasticity, fat clays		
	<b>OH</b>	Organic clays of medium to high plasticity, organic silts		



<b>HIGHLY ORGANIC SOILS</b>	<b>PT</b>	Peat, humus, swamp, soils with high organic contents
-----------------------------	-----------	--

		Local Access T.I. = 5			Collectors/Arterials T.I. = 7		
Soil Type (USCS)	r value	Ballast	Top Course	*Surfacing	Ballast	Top Course	Surfacing
OH,OL,CL, CH,MH	5	<b>DESIGN REQUIRED</b>					
	10						
	15						
SC	20	12"	4"	3"	18"	6"	4"
ML	25	12"	4"	3"	18"	6"	4"
	30	12"	4"	3"	18"	6"	4"
**GM,GL	35	12"	4"	3"	12"	6"	4"
SM	40	12"	4"	3"	12"	6"	4"
SP	45	12"	4"	3"	12"	6"	4"
	50	12"	4"	3"	12"	6"	4"
GP	55	12"	4"	3"	12"	6"	4"
SW	60	12"	4"	3"	12"	6"	4"
GW	65	12"	4"	3"	12"	6"	4"

\* See Road Standards for surfacing requirements. Local Road 'C' not maintained by county

\*\* GM & GC soils are highly dependent on the % silt or clay, a 35 r value is on the conservative side

### **6.19 TOP COURSE**

SIEVE SIZE	% PASSING
1"	100
3/4"	90-100
#4	40-65
#8	30-50
#200	3-9

A. At least sixty percent (60%) of the crushed aggregate particles retained on the No. 4 sieve shall have at least one (1) fractured face.

B. The Los Angeles Abrasion Test may be required to ensure the top course aggregate does not show more than a loss of thirty-five per cent (35%) and the sand equivalent not less than 30.

C. The material shall be placed in loose lifts not to exceed 6" in depth and compacted to the approved design depth. The material shall be mechanically compacted by rolling to ninety-five percent (95%) of the ASTM D-698 Proctor Density. Care shall be taken to see that the aggregate is placed in such a manner that it will have uniform mixture throughout.

D. Prior to placing top course material on the ballast, the Road and Bridge Director, The Engineer, or designated representative shall have the opportunity to observe and approve the ballast. The notification for the observation must be twenty-four (24) hours prior to the observation and must be requested for observation during the appropriate Bonner County Road and Bridge Department's normal working hours and work week.

E. Prior to requesting observation of the finished Top Course material, blue top stakes will be set to finished base elevations at fifty foot (50') stationing on curves and one hundred foot (100') stationing on tangents at centerline and shoulders.

F. The surface of any base course, when finished, shall be such that when tested with a ten foot (10') straightedge placed on the surface with its centerline parallel to and perpendicular to the centerline of the road, the maximum deviation from the surface of the edge of the straight edge shall nowhere exceed 0.04 of a foot. In addition, the finished grade shall not deviate more than 0.05 of a foot at any point from the staked elevation.

G. If hot mix asphalt surfacing is to be placed on the Top Course, no portion of the complete surface of the Top Course shall be more than 0.04 of a foot below the edge of a straight ten feet (10') in length laid parallel to and perpendicular to the centerline of the roadway. In addition, the finished grade shall not deviate more than 0.03 of a foot at any point from the staked elevation.

H. Should patching of any base course be necessary in order to meet the above tolerances, it shall be performed using methods and aggregates approved by the Road and Bridge Director, the Engineer, or designated representative.

## **6.20 HOT MIX ASPHALT SURFACING::**

A. The hot mix asphalt surfacing shall be used on **all public roads proposed for public maintenance.** The road shall meet the following requirements and shall be constructed under the observation of the Bonner County Road and Bridge Director or designee. Prior to placing any asphalt material on the top course, The Road and Bridge Director, the Engineer, or designated representative, shall have the opportunity to observed and approve the top course. The placement of the asphalt material must be observed and approved

by the Bonner County Road and Bridge Department. The notification for the observation must be twenty-four (24) hours prior to the observation and must be requested for observation during the appropriate Bonner County Road and Bridge Department's normal working hours and work week.

B. The mix used for the hot mix asphalt concrete must be a Bonner County approved asphalt mix design. Mix design characteristics must be submitted and approved by the Bonner County Road and Bridge Director, the Engineer, or a designated representative.

C. The asphalt mix shall be laid only when the ambient air temperature is greater than 45 degrees Fahrenheit and rising and the mix is at a temperature not less than 235 degrees Fahrenheit and not to exceed 280 degrees Fahrenheit.

D. After spreading, the mixture shall be thoroughly and uniformly compacted with power rollers. Rolling of the mix shall begin as soon after spreading as it will bear the roller without undue displacement or hairline cracking. Initial rolling shall be done longitudinally. The rollers shall overlap on successive trips. Alternate trips of the roller shall be slightly different lengths. Unless otherwise directed, the initial or breakdown rolling shall consist of one complete coverage of the paving mixture performed with a two-axle tandem roller. Initial breakdown rolling shall be followed by three complete coverages with a pneumatic tired roller while the temperature of the mixture is at or above 140 degrees Fahrenheit. The final rolling shall be performed by a three-axle steel wheeled tandem roller. Rolling shall be performed in such a manner that cracking, shaving, or displacement shall be avoided. Final rolling shall be completed the same day the pavement is placed. Sufficient rollers shall be furnished to handle the output of the plant. Rolling shall continue until all rolling marks are eliminated, and the surface is of uniform texture and true to grade and cross section. To prevent adhesion of the mixture to the rollers, the wheels shall be kept properly moistened. Excessive water or diesel fuel will not be permitted on the roller surfaces. The asphalt shall be placed in two (2) lifts or courses.

The final mat thickness after compaction shall be in accordance with the following:

Arterial Roads - 4"

Collector Roads - 4"

Local Access Roads A & B – 3"

Local Access Roads C – asphalt surface not required (Not to be County Maintained)

E. The completed Hot Mix asphalt concrete surface course shall have a field density equal to or greater than 92% Rice Density. Three or more consecutive tests below 92% will require corrective action.

F. The final surface shall be of a uniform texture and shall conform to lines and grade shown on the plans. Before final acceptance of the project or during the progress of the work, the thickness of all courses will be determined by the Bonner County Road and Bridge Director, the Engineer, or his designee. All unsatisfactory work shall be repaired, replaced or corrected.

G. Both density and thickness shall be carefully controlled during construction and shall be in full compliance with plans and specifications.

H. For the purpose of testing the surface on all courses, a 10 foot straightedge shall be used.

I. The straightedge shall be held in successive positions parallel and perpendicular to the street centerline in contact with the surface and the entire areas checked from one side to the other. Advances along the pavement shall be in successive stages of not more than the length of the straightedge.

J. Irregularities which may develop before the completion of rolling shall be remedied by loosening the surface mix and removing or adding materials as may be required. Any irregularities or defects which are found after the final rolling, which vary more than 0.02 of a foot in 10 foot for surface courses shall be corrected. All minor surface projections, joints and minor honey combed surfaces shall be repaired smooth to grade, as may be directed by the Bonner County Road and Bridge Director, the Engineer, or designee.

## **6.21 CHIP SEAL**

A chip seal surfacing shall be used on all **public roads proposed for public maintenance**. The road shall meet the following requirements and shall be constructed under the observation of the Bonner County Road and Bridge Director, the Engineer, or designee. Prior to placing any seal coat material on the hot mix asphalt concrete surfacing, The Road and Bridge Director, the Engineer, or designated representative, shall have the opportunity to observe and approve the asphalt material . The placement of the chip seal must be observed and approved by the Bonner County Road and Bridge Department. The notification for the observation must be twenty-four (24) hours prior to the observation and must be requested for observation during the appropriate Bonner County Road and Bridge Department's normal working hours and work week.

This work consists of an application of asphalt oil followed by an application of cover coat material, in accordance with these specifications:

A. Asphalt shall be CMS-2P or as approved by Bonner County Road and Bridge.

B. Cover coat material shall meet the following gradation and testing will be in accordance with AASHTO T11: materials finer than No. 200 Sieve in Mineral Aggregates by washing and AASHTO T27: Sieve Analysis of Fine and Course Aggregate.

<u>Sieve Size</u>	<u>Percent Passing</u>
5/8 inch	100
3/8 inch	30-55
No. 4	0-15
No. 8	0-5
No. 200	0-2

C. The workmanship and construction limitations are as follows:

1. Do not apply asphalt when roadway surface or weather conditions would prevent satisfactory construction.
2. The minimum pavement surface temperatures for applying asphalt shall be 80°F and rising.
3. Do not chip seal when pavement temperatures exceed 140°F. If bleeding on the completed chip seal becomes apparent, cease chip sealing operations and provide immediate maintenance and traffic control. Resume chip sealing operations after corrective actions have been initiated.
4. Do not chip seal when wind velocity exceeds 15 mph.
5. Allow asphalt cement mixes to cure a minimum of 30 days before applying chip seal.
6. Unless otherwise permitted by the Bonner County Road and Bridge Director, the Engineer, or designee, do not apply chip seal before June 15 or after September 1 to ensure that adequate time is available in the proper temperature range for the oil to set.

D. The equipment used for chip seal application shall meet the following requirements:

1. The asphalt oil applying equipment shall meet requirements for proper application.
2. Rotary broom(s) required.
3. Both pneumatic tire rollers and steel drum rollers are required to ensure good compaction on peaks and valleys. Do not operate roller at speeds in excess of 8 mph for the first coverage, nor in excess of 16 mph for subsequent coverages.

4. The self-propelled aggregate spreader shall be supported by at least four wheels equipped with pneumatic tires on two axles and equipped with positive controls so that the required amount of material will be deposited uniformly over the full width required.
- E. The following items are required with the application of the asphalt:
1. Clean surface and do not begin applying asphalt until surface has been approved by the Bonner County Road and Bridge Department.
  2. The quantity of asphalt per square yard shall be 0.48 gallons per square yard.
  3. If the texture of the surface is such that asphalt penetrates too rapidly, a preliminary application of from 0.05 to 0.10 gallons per square yard of surface may be required.
  4. Do not open spray bar unless distributor is moving forward at proper application speed.
  5. Correct any skipped or deficient areas and assure smooth riding surface at meet lines of spreads.
  6. Do not vary distribution of asphalt more than 15% transversely from the average nor more than 10% longitudinally as determined by Idaho T-80.
  7. Length of spread of asphalt is limited to that which a truck loaded with cover coat material can immediately cover.
  8. Place meet lines within one foot of lane lines or within two feet of center of lanes only. Do not place meet lines in wheel paths.
  9. Spread width of asphalt not to exceed six inches wider than the width covered by the cover coat material from the spreading device.
  10. Under no circumstances is the operation to proceed in such a manner that the asphalt will be allowed to chill, set up, dry or otherwise impair retention of the cover coat material.
  11. Do not allow the distributor spray bar or mechanism to drip on surface.
  12. Protect all utilities and utility covers by covering with building paper prior to spreading asphalt.
- F. The following items are required with the application of cover coat material:
1. The quantity of chips shall be 380 tons per mile, or 27 pounds per square yard.
  2. Spread in a manner that at no time the tires of the trucks or spreading equipment touch the uncovered asphalt.
  3. Do not allow vehicles to cross the meet line of newly applied cover coat material.
  4. Moisten cover coat material with water to eliminate or reduce dust coating on derogate if needed.
  5. Immediately after the cover coat material is spread, apply additional material to deficient areas.
  6. Begin rolling immediately behind the spreader. Apply eight complete roller coverages using a combination of steel drum and pneumatic tire rollers.
  7. Complete rolling prior to allowing vehicular traffic to the surface.

8. Operate equipment at a speed and in a manner which eliminates the turning or displacement of cover coat material.
9. Prior to brooming, apply sufficient reject material in areas directed to absorb free asphalt.
10. Sweep excess material from entire roadway surface by means of rotary brooms after placing material.
11. Conduct brooming in a manner that does not displace any embedded cover material.
12. Pick up and dispose of excess material in curb and gutter sections as directed.
13. Broom is to be in good condition and capable of sweeping a path without loosening or displacing embedded material.
14. When brooming operations could create dust to the extent that it would violate air pollution regulations or create a safety hazard, lightly spray the surface of the roadway to be swept with enough water to prevent dust from becoming airborne.

## **6.22 SIGNAGE, STRIPING AND/OR PAVEMENT MARKINGS**

- A. No new road shall be considered completed until the following signs, pavement markings (railroad crossings and stop bars) and road striping on arterials and collectors, are completed. Pavement markings shall be shown on the road plans, and shall be completed in accordance with the Manual on Uniform Traffic Control Devices. Paint quality shall be equivalent to that used by the Idaho Transportation Department for pavement markings.

<b>Road Classification</b>	<b>Stop Sign</b>	<b>Stop Bar</b>	<b>**Road Name</b>	<b>Fog Line</b>	<b>Center Line</b>	<b>Railroad Crossing</b>
<b>ARTERIAL</b>	<b>X</b>	<b>X</b>	<b>X</b>	<b>X</b>	<b>X</b>	<b>X</b>
<b>COLLECTOR</b>	<b>X</b>	<b>X</b>	<b>X</b>	<b>X</b>	<b>X</b>	<b>X</b>
<b>LOCAL ROAD</b>	<b>X</b>	<b>X</b>	<b>X</b>			<b>X</b>

\*\*Approved road name signs shall be installed to the satisfaction of the Bonner County Road and Bridge Department.

- B. All signing, striping and pavement markings must be approved after their installation by the Bonner County Road and Bridge Department. The notification for the observation must be twenty-four (24) hours prior to the observation and must be requested for observation during the appropriate Bonner County Road and Bridge Department's normal working hours and work week.
- C. Passing zones in the striping shall be determined using the following requirements:

Design Speed (MPH)	<b>25</b>	<b>35</b>	<b>45</b>	<b>55</b>
Stopping Sight Distance (Feet)	155	250	360	495
Minimum Required Sight Distance to Start a Passing Zone (Feet)	940	1040	1458	1918
Minimum Sight Distance Remaining to End Passing Zone (MUTCD Table 3B-1) (Feet)	450	550	700	900

### **6.23 STANDARDS FOR NEW BRIDGE CONSTRUCTION**

The standard for bridge design shall at a minimum be HS-25, as described in the AASHTO Policy on Geometric Design of Highways and Streets, with the requirement that bridge design meet the legal load limit for the respective road type.

The minimum width of a bridge structure from the interior faces of the curb or the interior faces of the guardrail or bridge rail shall be the full width of the approach road (including pavement or roadway width and shoulders).

The minimum vertical clearance for bridge structures from the surface of a waterway shall be two (2) feet above the one hundred (100) year flood elevation of the waterway. The minimum vertical clearance for bridge structures from the surface of a roadway below shall be sixteen (16) feet.

### **6.24 OBSERVATION FEES**

All required observation and approvals by the Road and Bridge Director, the Engineer, or designee shall require the developer to pay a fee as set forth by Resolution of the Bonner County Board of Commissioners.

### **6.25 ENGINEERING REQUIREMENTS**

#### **INSPECTIONS REQUIRED**

The project engineer shall, at a minimum, conduct on site inspections of the new road construction at the following points:

1. Completion of construction surveying and staking.
2. Completion of sub grade, prior to the placement of any ballast material.
3. Completion of ballast, prior to the placement of any top course material.
4. Completion of the top course, prior to the placement of hot mix asphalt.
5. Completion of the hot mix asphalt.
6. Completion of the chip seal.
7. Completion of any road finishing ( such as pavement striping or marking), installation of road signs, installation of any appurtenant structures, and reseeding of disturbed area and slopes.



## **6.26 FINAL REPORT AND AS-BUILT DRAWINGS**

At the completion of the road construction, and following the last required inspection, the project engineer shall submit a final report and a set of as-built drawings for the new road and any appurtenant structures. The final report shall include complete information related to the road construction and at a minimum, include the following information:

1. Dates of inspection, work performed and inspected, changes or repairs ordered.
2. Weather conditions, unusual or unexpected site conditions.
3. Engineering operations performed.
4. Manufacturer's certificates for materials and /or certified test results and all preliminary tests to insure suitability of materials.
5. The appropriate INSPECTION AND INFORMATION CHECKLIST.

## **6.27 DEDICATION OF ROAD FOR PUBLIC MAINTENANCE**

After completion of the road construction, and submission of the required reports; the developer shall request to the Director the dedication of the public road for public maintenance. The Director will prepare the required forms and submit them to the Bonner County Board of Commissioners for their action. The Bonner County Board of Commissioners reserves the right to deny acceptance of the road into the maintenance system.

**REQUIRED INSPECTION & INFORMATION CHECKLIST**

Check off when completed & submit to Bonner County Road and Bridge Department

PROJECT NAME: \_\_\_\_\_

ASSIGNED PLANNING DEPARTMENT NUMBER: \_\_\_\_\_

ASSIGNED ROAD AND BRIDGE ENCROACHMENT PERMIT NUMBER: \_\_\_\_\_

**For all public roads:**

- Project Engineer shall submit construction inspection notes
- Verify placement of the approved geotextile fabric, ballast and 3/4" minus
- Verify the gradation of 3/4" minus and ballast, submit sieve analysis
- Verify the section depth
- Submit nuclear density gauge field data sheets
- Submit sub grade Density Test results
- Density tests are required for every lift at a minimum frequency of 300 linear feet, for all materials, special attention shall be paid to curve returns, cul-de-sacs or sensitive areas
- Submit proctor tests results on sub grade, ballast, 3/4" minus
- (Other requirements as per ISPWC – verified by Engineer)

**For all public roads, publicly maintained submit the above and:**

- Asphalt mix design
- Asphalt placement
- Asphalt compaction
- Chip Seal placement

**CERTIFICATION OF COMPLETION/ACCEPTANCE:**

I CERTIFY THE PROJECT IS COMPLETED IN GENERAL ACCORDANCE WITH THE APPROVED PLANS AND SPECIFICATIONS.

\_\_\_\_\_  
Project Engineer Signature Date:

\_\_\_\_\_  
Project Engineer Name PRINTED Seal

## **SECTION 7: STANDARDS FOR CONSTRUCTION AND MAINTENANCE OF PRIVATELY MAINTAINED PUBLIC ROADS**

### **7.1 GENERAL REQUIREMENTS**

Construction of new roads built in public right-of-ways which are proposed for private maintenance shall conform to the standards set forth in this Section.

It is the intent of this section to allow as much freedom to the public as possible in how they wish to maintain the roads for their own use, while still preserving the access rights and protecting the interests of the greater public use and safety. The Director or his designee may grant variances to the standards in this section if unusual circumstances exist which place undue burden on the public attempting to improve or use an existing primitive and/or under-developed public right-of-way.

New construction, re-alignment, or changes to significant features and/or geometry of roads or driveway approaches in the public right-of-way shall require encroachment permits. Any action which limits the access, use, or maintenance of the right-of-way by the public will not be allowed. Idaho Code, Section 40-203 (5), speaks to obstruction of the public right-of-way and the misdemeanor offense involved.

Maintenance activities such as grading, ditching, brushing, replacing culverts, or replacing top course materials shall not require a permit so long as they do not result in a restriction of access, use, or maintenance by the public. See Subsection 7.26 for more details.

Utility installations in the public right-of-way shall require a utility permit.

Under no circumstances, including emergencies, will Bonner County Road and Bridge assist in maintenance of privately maintained roads without acceptance of the road into the Bonner County Road Maintenance Plan by the Board of County Commissioners. Said road must be constructed to the standards as outlined in Section 6 prior to consideration for acceptance.

### **7.2 BONDING FOR PRIVATELY MAINTAINED ROADS**

A. Bonds for privately maintained road construction up to 100% of the construction costs and for a length of 1 year may be required by the Director if the interests of the public are at stake. Bonds shall be in the same format as discussed in previous sections.

### **7.3 DESIGN & LAYOUT**

A. The Idaho Standards for Public Works Construction (ISPWC), the most recent edition, and the most recent edition of the Policy on Geometric Design of Highways and Streets published by the American Association of State Highway and Transportation Officials (AASHTO) shall serve as guides for project engineers in the design of all new roads within public right-of-ways.

### **7.4 SPECIFICATIONS FOR DRAWINGS FOR NEW ROAD CONSTRUCTION (PRIVATELY MAINTAINED PUBLIC ROADS)**

A. The Project Engineer shall prepare road and right-of-way drawings, and each sheet of the drawings shall bear the seal of said engineer. A licensed surveyor may prepare the right-of-way drawings, and each sheet of the drawings shall bear the seal of said surveyor.

B. Two (2) copies of the design drawings shall be submitted to the Bonner County Road and Bridge Department for review. All drawings shall include the following when applicable:

17. The first sheet of the plans shall include a project title, vicinity map, and index of plan sheets.
18. Road alignments with 50' stationing, reading from left to right, and stationing at point of curve, tangent, and intersections, with appropriate ties to existing road surveys and stationing, section corners, quarter corners, and the horizontal control established by the engineer. Stations shall increase from west to east and from south to north.
19. Section, township and range.
20. Bearings on the road centerline, keyed to an associated plat map.
21. Curve data including radius, delta, arc length, and semi-tangent length, on all road centerlines and curb returns.
22. Right-of-way lines, width for proposed road, intersecting roads, and existing road improvements with dimensions.
23. All topographic features within right-of-way limits or future right-of-way limits and sufficient area beyond to resolve questions of setback, slope, drainage, access onto abutting property, and road continuations.
24. All existing utilities.
25. All proposed water and sewer utilities that will be designed and constructed.
26. Identification of all roads and adjoining subdivisions.
27. A Traffic Control Signing Plan and Striping Plan.
28. Existing and proposed drainage features, showing direction of flow, size and kind of each drainage channel, pipe, and structure and other specified requirements in any county storm water management specifications.
29. Horizontal Scale: 1" = 50' and a Vertical Scale of 1" = 10'. However, 1" = 100' shall be optional for development of lots one acre or larger. Details

- for clarification may be shown on a convenient scale. A scale of 1" = 20' may be required for urban arterial streets where detail is sufficiently dense to cause a "cluttered" drawing at a smaller scale.
30. A north arrow.
  31. Project beginning and ending designation with stations.
  32. A title block to include:
    - f. The project name
    - g. County Project Number
    - h. Sheet number
    - i. Road names
    - j. Road limits
  18. All found and referenced survey monuments.
  22. Section and lot lines.
  23. Beginning, middle, and ending elevations of curb returns.
  24. Other data necessary for the specific project.
  22. Project construction detouring and traffic control requirements.

**7.5 WIDTHS REQUIRED FOR NEW CONSTRUCTION OF PRIVATELY MAINTAINED PUBLIC ROADS\***

A. New roads shall have a minimum right-of-way and travel width based on the classification of the road as follows:

Classification of road	Minimum Right-of-way	Roadway Width	Travelway Width	Asphalt Surface
Collector	60 feet	34 feet	24 feet	no
Local Roads w/ more than 200 ADT	60 feet	26 feet	24 feet	no
Local Roads w/ less than 200 and more than 50 ADT	60 feet	24 feet	22 feet	no
Local Roads w/ less than 50 ADT	60 feet	12 feet**	10 feet**	no

All new road rights-of-way shall be of sufficient width to accommodate all cuts or fills. Where extreme cut or fill sections cannot be contained within the minimum right-of-way, additional right-of-way width will be required.

ADT shall be the anticipated traffic based on Trip Generation calculations, land use, number of lots served, etc.

\*\* Greater, if required by the local Fire District.

**7.6 ROAD DESIGN FOR PRIVATELY MAINTAINED ROADS**

The Typical rural road section shall be designed in accordance with Plate 8, Typical Road Cross Section – Privately Maintained Public Roads. Road and

Bridge reserves the right to specify the required material gradations for each course of rock. The minimum and maximum for design parameters of new privately maintained roads shall be:

DESIGN PARAMETER	COLLECTOR	LOCAL ACCESS ROAD
Vertical grades	Min. 0.5% Max. 10%*	Min. 0.5%, Max. 16%*    Max for cul de sac 2%
Horizontal curvature on centerline	Min. radius of 510 ft.	Min. radius of 100 ft.
Design speed	35-45 mph	25-35 mph
Super elevation	Max. of 0.06 ft./ ft. Min. of 0.02 ft/ft	Max of 0.06 ft./ ft. Min. of 0.02 ft/ft
Minimum run out length	120 ft.	110 ft.

\*8-16% grades allowed for no more than 200 feet in length, 100 feet between grade sections with a break. No horizontal curves allowed within 100 feet of the 8-16% grade.

## **7.7 ROAD INTERSECTIONS**

A. All new roads which intersect existing public roads and rights-of-way shall intersect at an angle which is between eighty (80) and ninety (90) degrees, and as close to ninety (90) degrees as is possible. The edge of the road surfaces shall be connected with a curve having a minimum radius of thirty (30) feet, as depicted in Plate 1, Standard Approaches. The road surface in cul de sac bulbs shall be connected with the road surface providing access to it with a curve having a minimum radius of thirty-five (35) feet, as depicted in Plate 4, Standard Cul de sac Layout.

B. The road approach area is used for vehicle storage while waiting to enter an intersection, and shall be designed with a nearly flat grade. For public roads publicly maintained or public roads privately maintained, the road approach area at a stop controlled intersection (e.g. stop sign, yield sign, or traffic signal) shall have a downgrade approaching the intersection of no greater than 2%. An upgrade approaching the intersection shall be no steeper than 4%. The minimum length of the road approach area, measured from the edge of curb

# PLATE 8: TYPICAL ROAD CROSS SECTION PRIVATELY MAINTAINED PUBLIC ROADS

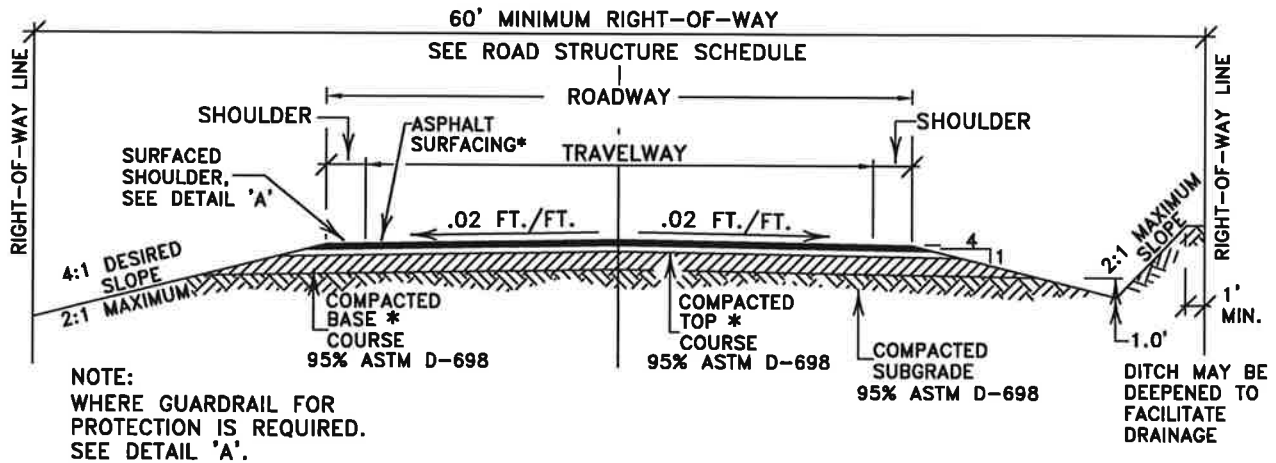

**TYPICAL RURAL ROAD SECTION**  
NOT TO SCALE

**NOTES:**

- 1). AT A MINIMUM, RIGHT-OF-WAY SHALL BE CLEARED FROM TOE OF SLOPE TO TOP OF CUT.
- 2). UTILITY CORRIDOR CLEARING MAY BE REQUIRED.
- 3). GEOTEXTILE PRODUCTS MAY BE REQUIRED WITH CERTAIN SUBGRADES.
- 4). EXPOSED SLOPES SHALL BE RESEEDED AS SOON AS POSSIBLE AFTER CONSTRUCTION COMPLETION.

**LOCAL ROADS**

- A = MORE THAN 200 ADT
- B = BETWEEN 50 AND 200 ADT
- C = LESS THAN 50 ADT

### ROAD STRUCTURE SCHEDULE \*

CLASS OF ROAD	TOP COURSE	BASE COURSE	TRAVELWAY WIDTH (FT.)	ROADWAY WIDTH (FT.)
COLLECTOR	6"	12"-18"	24'	34'
LOCAL ROAD 'A'	4"	12"	24'	26'
LOCAL ROAD 'B'	4"	12"	22'	24'
LOCAL ROAD 'C'	4"	12"	10'	12'

\* SEE SECTION 7 FOR OTHER REQUIREMENTS

face, or traveled way where curbs are not present, is to be in accordance with the Table below. For any road classification not listed in the Table, the Road and Bridge Director may require a traffic analysis to determine the road approach length.

Average Daily Traffic (ADT)	Minimum Road Approach Length (2% Maximum Down Grade and 4% Maximum Upgrade)	
	Local Access Streets	Collector/Arterials
ADT < 200	25 Feet	50 Feet
200 < ADT < 400	50 Feet	75 Feet
400 < ADT < 1000	75 Feet	100 Feet
1000 < ADT	75 Feet	Analysis required

### **7.8 CURB AND GUTTER DESIGN**

Where curbs and gutters are planned or required, the parameters illustrated in Plate 6, Typical Curb and Gutter Construction, shall serve as a design guide, except for road widths. For road widths of privately maintained roads, see Plate 8.

### **7.9 DRAINAGE ALONG/ ACROSS PRIVATELY MAINTAINED ROADS**

A. Ditchlines are intended to be designed, constructed and used as a conveyance system for stormwater which originates on the roadway surface. They are not intended, nor shall they be used for the retention and infiltration of stormwater. It shall not be the responsibility of the roadside ditch to serve as a drain for private property.

B. Culverts across new roads shall be a minimum of twelve (12) inches in diameter, and shall be sized to carry the flow of the watercourse calculated with the discharge anticipated from a fifty (50) year design storm. Culverts shall extend beyond the toe of any fill. Culvert installation shall substantially conform to the specifications shown on Plate 7, Typical Culvert Installation, and the ISPWC manual specifications.

### **7.10 STOPPING AND PASSING SIGHT DISTANCES FOR NEW PRIVATELY MAINTAINED ROADS**

The minimum stopping and passing sight distances for new roads (where striped) shall be:



**Table 4: Stopping and Passing Sight Distance Requirements**

Design Speed (MPH)	25	35	45	55
Stopping Sight Distance (Feet)	155	250	360	495
Minimum Required Sight Distance to Start a Passing Zone (Feet)	940	1040	1458	1918
Minimum Sight Distance Remaining to End Passing Zone (MUTCD Table 3B-1) (Feet)	450	550	700	900
K* Value for Sag Vertical Curve	26	49	79	115
K* Value for Crest Vertical Curve	12	29	61	114

\*K value is a coefficient by the algebraic difference in grade may be multiplied to determine the length in feet of the vertical curve which will provide the minimum sight distance. K is calculated as follows:  $L/A=K$ , where L is the horizontal distance in feet and A is the algebraic difference between the intersection of tangent grades divided by the length of the curve in feet equals A/L in percent per foot. The reciprocal is the distance in feet required to affect a one percent (1%) change in gradient, commonly called K.

(The following values are assumed for sight distance design: A. Driver's eye height: 3.50 ft. for computation of stopping sight distance. B. Object height: 4.25 ft. for computation of passing sight distance and 0.50 ft. for computation of stopping sight distance. C. Perception/ reaction time: assumed equal to 2.5 seconds for stopping sight distance.) (add striping standards (passing zone length/sight distance requirements, etc.....

### **7.11 VISIBILITY AT INTERSECTIONS**

At intersections a minimum clear sight triangle shall be maintained as illustrated on Plate 2, Sight Triangle at Intersections.

### **7.12 APPURTENANT STRUCTURES**

All retaining walls in excess of four (4) feet in height within the right-of-way shall be designed by a Professional Engineer Licensed in the State of Idaho and will require an encroachment permit.

A. Guardrails: Guardrail may be necessary in certain areas depending upon the warrants for protection of the traveling public. The Bonner County Road and Bridge Department reserves the right to determine the need for guardrail under each separate circumstance when a new road is being constructed. The warrants for determining need of guardrail shall be made using the AASHTO Roadside Design Guide, latest edition.

The type of guardrail to be installed shall be determined by Bonner County Road and Bridge Department as location and maintenance coordination dictate.

B. Cattle guards: Cattle guards shall be constructed in conformance with the Manual for Highway & Street Standards prepared by the Local Highway Technical Assistance Council. An encroachment permit shall be required for the

installation of a cattle guard. Cattle guards must be maintained in a manner which allows un-restricted access by the public.

Idaho Code, Section 40-2310, regulates the installation of cattle guards on local highways and should be referenced when the question arises. It is encouraged to place them on private property, when necessary on private approaches.

Idaho Code, Section 40-203 (5), speaks to obstruction of the public right-of-way and the misdemeanor offense involved.

### **7.13 REVIEW FEES**

All required reviews and approvals by the Road and Bridge Director designee shall require the Applicant to pay a fee as set forth by Resolution of the Bonner County Board of Commissioners.

### **7.14 CLEARING AND GRUBBING FOR NEW PRIVATELY MAINTAINED ROAD CONSTRUCTION**

Prior to the start of road construction, grubbing within the roadway section on all public roads shall be completed. All materials removed by clearing or grubbing from the roadway shall be properly disposed of out of the right-of-way and in compliance with State and Local Permits. All denuded areas shall be hydro seeded at the end of the project or as specified in the Storm water and Erosion Control Plan.

### **7.15 EROSION CONTROL ON PRIVATELY MAINTAINED ROAD CONSTRUCTION**

During road construction, erosion control measures shall be installed and maintained to minimize soil erosion from disturbed sites. Permanent erosion control measures shall be included in all road designs, with design guidance from the Handbook of Best Management Practices for Stormwater Management and Erosion and the Idaho Standards for Public Works Construction. Refer to Chapter 24 of Title 12, of the Bonner County Revised Code for Stormwater Management and Erosion Control Plan requirements.

### **7.16 SIGNAGE ON PRIVATELY MAINTAINED NEW ROAD CONSTRUCTION**

- D. No new gravel road shall be considered completed until the following signs are completed. Sign locations shall be shown on the road plans, and shall be completed in accordance with the Manual on Uniform Traffic Control Devices. Signs shall be retroreflective.

<b>Road Classification</b>	<b>Stop Sign</b>	<b>Road Name</b>	<b>Railroad Crossing</b>
--------------------------------	----------------------	----------------------	------------------------------

			Sign
COLLECTOR	X	X	X
LOCAL ROAD	X	X	X

\*\*Approved road name signs shall be installed to the satisfaction of the Bonner County Road and Bridge Department.

\*\*\*Roads with asphalt surfacing shall refer to the pavement marking requirements of Section 6.

- E. All signing, striping and pavement markings must be approved after their installation by the Bonner County Road and Bridge Department.

### **7.17 STANDARDS FOR NEW BRIDGE CONSTRUCTION ON PRIVATELY MAINTAINED ROADS**

To protect the traveling public, who would assume that any bridge on a public road be capable of supporting standard loads, the standard for bridge design shall at a minimum be HS-25, as described in the AASHTO Policy on Geometric Design of Highways and Streets, with the requirement that bridge design meet the legal load limit for the respective road type.

The minimum width of a bridge structure from the interior faces of the curb or the interior faces of the guardrail or bridge rail shall be the full width of the approach road (including pavement or roadway width and shoulders).

The minimum vertical clearance for bridge structures from the surface of a waterway shall be two (2) feet above the one hundred (100) year flood elevation of the waterway. The minimum vertical clearance for bridge structures from the surface of a roadway below shall be sixteen (16) feet.

The Director may grant variances to the standards in this subsection if unusual circumstances exist which place undue burden on the public attempting to improve, replace, or use an existing bridge which experiences less than 50 ADT.

### **7.18 ENGINEERING REQUIREMENTS FOR NEW ROAD CONSTRUCTION (PRIVATELY MAINTAINED)**

#### **INSPECTIONS REQUIRED**

The Project Engineer shall, at a minimum, conduct on site inspections of the new road construction at the following points:

8. Completion of construction surveying and staking.
9. Completion of sub grade, prior to the placement of any ballast material.
10. Completion of ballast, prior to the placement of any top course material.
11. Completion of the top course, prior to the placement of hot mix asphalt.
12. Completion of the hot mix asphalt (if any).

13. Completion of the chip seal (if any).
14. Completion of any road finishing ( such as pavement striping or marking), installation of road signs, installation of any appurtenant structures, and reseeding of disturbed area and slopes.

#### **7.19 FINAL REPORT AND AS-BUILT DRAWINGS FOR PRIVATELY MAINTAINED NEW ROAD CONSTRUCTION**

At the completion of the road construction, and following the last required inspection, the Project Engineer shall submit a final report and a set of as-built drawings for the new road and any appurtenant structures. The final report shall include complete information related to the road construction and at a minimum, include the following information:

6. Dates of inspection, work performed and inspected, changes or repairs ordered.
7. Weather conditions, unusual or unexpected site conditions.
8. Engineering operations performed.
9. Manufacturer's certificates for materials and /or certified test results and all preliminary tests to insure suitability of materials.
10. The appropriate INSPECTION AND INFORMATION CHECKLIST.

#### **7.20 MAINTENANCE OPERATIONS FOR PRIVATELY MAINTAINED ROADS**

- A. Once a privately maintained road has been constructed to the standards listed above, or is already existing, maintenance is largely at the discretion of the public using the road.
- B. Maintenance operations such as grading, ditching, brushing, replacing culverts, snow plowing, or replacing top course materials shall not require an encroachment permit so long as they do not result in a restriction of access, use, or maintenance by the public.
- C. Maintenance of utilities which require digging will require a utility permit.

#### **7.21 ENCROACHMENTS ON PRIVATELY MAINTAINED ROADS**

- A. All requirements of Sections 2, 3, and 4 of this manual are in effect on privately maintained roads.
- B. All new driveways, or changes to existing driveways, shall require encroachment permits.
- C. No appurtenant structures may encroach on the public right-of-way without a permit. This includes, but is not limited to: retaining walls, boulders, fences, gates, arches, bollards, eco-blocks, sculptures, etc.

C.

## **SECTION 8: MAILBOXES AND NEWSPAPER DELIVERY BOXES**

### **8.1 APPLICABILITY**

All mailboxes and newspapers delivery boxes located within County rights-of-way shall conform to the standards set forth in this section.

### **8.2 STANDARDS**

No mailbox or newspaper delivery box (hereafter referred to as mailbox) will be allowed within the County right-of-way if it interferes with the traveling public or the function, maintenance or operation of the roadway system. The location and construction of mailboxes shall conform to the rules and regulation of the U.S. Postal Service and the following standards established based on A Guide for Erecting Mailboxes on Highways, published by the American Association of State Highway and Transportation Officials, 1994.

### **8.3 LOCATION**

A. The ROADSIDE FACE OF THE BOX SHALL BE OFFSET THE FOLLOWING DISTANCES:

- Paved road- the width of the shoulder plus one foot.
- Gravel road- one foot from the edge of the traveled portion on the roadway.
- Curbed street- one foot from the face of the curb

B. Where a mailbox is located at an intersecting road it shall be placed a minimum of 100 feet beyond the center of the intersecting road in the direction of the delivery route. This distance should be increased to 200 feet when the average daily traffic on the intersecting road exceeds 400 vehicles per day.

C. Where a mailbox is installed in the vicinity of an existing guardrail, whenever practical, it shall be placed behind the guardrail.

D. Mailbox turnouts are encouraged on all new road construction and on reconstruction.

### **8.4 STRUCTURE**

A. Mailboxes shall be constructed from sheet metal, plastic or similar weight materials and shall not exceed 11 pounds. No more than two mailboxes shall be mounted on a support structure unless the support structure and mailbox arrangement have been shown to be safe by crash testing, approved by the U.S.

Department of Transportation. Newspaper boxes may be mounted below the mailbox on the side of the mailbox support.

B. Multiple mailbox installations must meet the same criteria as do single mailbox installations. This requirement precludes the use of a heavy horizontal support members. It is recommended that mailbox supports be separated a distance at least equal to three-fourths of their heights and preferably their full heights above ground. It is also preferred that multiple mailbox installations be located outside the road clear zone.

C. A single 4 inch x 4 inch square or 4 inch diameter wooden post, or a metal post with strength no greater than a 2-inch diameter standard steel pipe and embedded no more than 24 inches into the ground will be acceptable as a mailbox support. A metal post shall not be fitted with an anchor plate, but may have an anti-twist device that extends no more than 10 inches below the ground surface. Larger wooden posts may be used provided the posts have drilled holes and the support design has been shown to be safe by crash testing, approved by the U.S. Department of Transportation.

D. The post-to-box attachment details should be of sufficient strength to prevent the box from separating from the post top if the installation is struck by a vehicle.

#### **8.5 REMOVAL AND LIABILITY**

The owner, upon notification by the Road and Bridge Department, shall remove any new mailbox installation that is in violation of Section 7. Bonner County shall not be liable for damage to any mailbox that does not meet the requirements of section 7, nor is it liable for any damage due to an installation being damaged by snow during snow removal operations.

## SECTION 9: BONNER COUNTY TRAFFIC IMPACT STUDY GUIDELINES

This section describes the traffic impact study requirements of Bonner County and those agencies that wish to adopt Bonner County traffic study requirements. Traffic impact study requirements will be identified by County or Agency Planning and/or Road and Bridge staff during pre-application discussions/reviews, and submittal will be required prior to project approval. Improvements or strategies identified by the traffic impact study to mitigate traffic and transportation impacts will become a condition of building and/or occupancy permits, and shall be constructed prior to the issuance of said permit; unless specified otherwise by the agency.

An applicant wishing to pursue a land use action within Bonner County shall first submit a ***trip generation and distribution letter*** to the County for review. The Road and Bridge Department will use this letter to help determine whether a ***traffic impact study*** should be required for the proposed land use action/project.

### **Trip Generation and Distribution Letter**

A trip generation and distribution (TG&D) letter shall be required of all applicants wishing to pursue land use actions within Bonner County. This includes actions for both new and redevelopment land use actions. The purpose of the TG&D letter is intended to help the Road and Bridge Department determine whether a traffic impact study will be required for the development. The letter should be submitted shortly following pre-application discussions/interviews, as to provide the applicant sufficient time to develop a traffic impact study, if required by the Road and Bridge Department, prior to project approval. The information provided within a TG&D letter should include:

- **Project Location.** A written description of the project location in relation to state highways, major, and/or minor arterials located within the vicinity of the project site. The site should also be displayed graphically on an attached figure.
- **Project Action.** A written description of the land use actions should be provided. The description should include: use and size of the project (both site area and, as available, building area); existing and proposed zoning; project access locations; and development/phasing and completion schedules. A graphical site plan is desired as an attached figure, when possible.
- **Trip Generation.** The study should identify the number of trips anticipated with project development. Trip generation should be determined based upon the methodologies of the most current, Institute of

Transportation Engineers (ITE) Trip Generation Manual (current edition); unless trip generation data more applicable to the proposed land use can be presented by the applicant. The Road and Bridge Department will determine whether supplemental trip generation data can be utilized. When relevant, total project trips will be separated into trip types (i.e. new, pass-by, diverted, and shared) to better describe the traffic characteristics of retail and commercial developments. Trip types shall also be identified using ITE resources or some other means acceptable to the Road and Bridge Department. Project trip generation shall be provided for the typical weekday, weekday AM peak hour, and weekday PM peak hour only; unless the Road and Bridge Department specifies some other time period for analysis (i.e. Saturday or Sunday peak hours).

- **Trip Distribution and Assignment.** A description of project trip distribution and assignments will be provided in the study. The methodologies used to distribute and assign project trips will be discussed/provided in the TG&D letter. As a guide, trip assignments should be provided for site access and key intersections located within the direct vicinity of the site, and for those key intersections projected to support more than 25 peak hour trips beyond the immediate site vicinity during the typical weekday or other time period specified by the Road and Bridge Department.

### **Traffic Impact Study**

A traffic impact study (TIS) is intended to forecast and, as needed, mitigate the transportation and traffic impacts of a proposed land use development or redevelopment project. A TIS will be required at the discretion of the Road and Bridge Department; however, the Road and Bridge Department will typically require a TIS when one or more of the following conditions are met:

- Project is projected to generate more than 50 trips during the AM and/or PM peak hours (or some other time period specified by the Road and Bridge Department).
- The Road and Bridge Department anticipates that project driveway trips will significantly impact traffic operations on adjacent arterials.
- The project is proposed along a route(s) that historically experiences or is projected to experience traffic safety issues.
- The project is proposed within the vicinity of a school, community park, or some other area with high levels of pedestrian and neighborhood activity.

The scope and extent of the TIS is also established at the discretion of the Road and Bridge Department. Generally, the TIS will address traffic conditions/operations during the single hour of peak traffic activity during the typical weekday (i.e. peak “rush hour”) on adjacent streets. In some instances, adjacent street activity will not vary significantly throughout the day, thus requiring the analysis of multiple peak hour conditions. Similarly, the project may generate significant levels of traffic during multiple periods of the day; thus, the



Road and Bridge Department may require additional analysis periods. The Road and Bridge Department also may request an analysis of other time periods such as peak hours during the typical Saturday or Sunday, when relevant.

For those land use projects that generate between 50 and 99 peak hour trips, the Road and Bridge Department will typically require the TIS to address traffic operations/conditions at site driveways and at key intersections located immediately upstream/downstream of the project site. For those projects that generate greater than 100 peak hour trips, the Road and Bridge Department may elect to include additional intersections that experience a net increase of more than 25 peak hour trips.

The TIS will be developed and submitted prior to project approval. Any improvements/mitigations required of a project will be expected prior to the issuance of a building and/or occupancy permit as project phasing thresholds are realized or the project is completed and ready for occupancy. Project mitigations will be required at the discretion of the Road and Bridge Department; however, the Road and Bridge Department will work to assure that improvements are proportionate to the level of the projects impact. Typically, the applicant can expect one or more of the following:

- **Frontage Improvement:** Frontage improvements provide the Road and Bridge Department the opportunity to progress road, drainage, and pedestrian/bicycle accommodations in a manner consistent with current Bonner County Road Standards. Frontage improvements would extend along roadways within property boundaries and can include, but would not be limited to, half-road improvements, sidewalk/pathway construction, bike lanes, parking lanes, drainage areas, and landscape buffers.
- **Direct Mitigation:** The Road and Bridge Department may require a project to directly improve a street or intersection that experiences a proportionate increase of traffic, as the result of project development. Typical improvements include, but are not limited to, channelization/turn lane construction/extension, signal implementation, road widening, sidewalks, bike lanes, parking lanes, drainage areas, etc.
- **Partial Mitigation.** The Road and Bridge Department may allow an applicant to participate proportionately with other applicants and/or other public entities to construct improvements that are not exclusively the responsibility of any single applicant or entity. The applicant could share a proportionate percentage of the costs associated with turn lane construction, signal implementation, road widening, sidewalks, bike lanes, parking lanes, drainage areas, etc. The projects proportionate share of an improvement is typically determined by dividing project trip assignments along a roadway section or at an intersection by total projected volumes.

In addition to the project location, project action, trip generation, and trip distribution/assignment information required of the TG&A letter, a TIS report must also include the following:

- **Introduction.** The introduction must define the purpose of the TIS, provide a project description, discuss the scope and extent of the study, and discusses methodology and assumptions. The introduction should also provide the site location and description information, as highlighted by the TG&D section, for the TIS. Site location and site plan figures are required with the TIS.
- **Roadway Inventory.** A TIS must provide a description of the transportation network located within the project study area, as established by the Road and Bridge Department. These descriptions include roadway classifications, roadway channelization, speed limits, intersection controls (signal, stop-controlled, traffic calming techniques, etc.), intersection channelization (includes turn lane storage), etc. A figure highlighting roadway characteristics (class, lanes, and speeds), and intersection channelization and controls is recommended.
- **Traffic Counts.** Recent weekday and peak hour traffic counts must be secured for study arterials and intersections. Average daily traffic/24-hour (weekday) counts must be secured for at least one location on primary study arterials. Intersection turn movement counts must be obtained for study intersections identified by the Road and Bridge Department for peak study hours. Counts conducted 2 years prior to study initiation cannot be used in the TIS and must be updated. A figure that summarizes existing turn movement counts is required in the TIS. Weekday counts can either be summarized graphically or in a table within the TIS. Raw count data should be included in an appendix to the TIS.
- **Accident Histories (Discretionary).** The Road and Bridge Department may require collision histories for roadways and intersections located within the study area. Typically, the most current 3-year period of collision activity is requested from ITD and/or local officials. The data is examined to summarize accident and severity activities; highlight the reoccurrence of particular accident types; and sometimes to examine accident frequency/rates as compared with Idaho State averages.
- **Programmed Improvements.** The TIS must describe any improvements that are programmed by agencies or other developments, as they may influence travel patterns or capacity within the study area. Programmed improvements must be factored, as necessary, within traffic forecasts and the future operations analysis. A figure highlighting programmed improvements is recommended. The County and State Engineer, local transportation improvement program documentation, and other TIS traffic studies are typical resources to identify future improvements. The source for each improvement must be identified within the TIS.
- **Baseline (Without-Project) Forecasts.** Baseline traffic volumes should be developed for the forecast horizon/build-out year of the proposed project. Forecast traffic volumes will be developed by using a specific annual growth rate, as identified through historical traffic counts and confirmed by the Road and Bridge Department or as obtained directly

from the Road and Bridge Department. As necessary, the trips generated by recently approved, concurrently developing projects should be included into baseline forecast projections. The Road and Bridge Department will identify these “pipeline” projects and should typically be able to provide trip assignments from other relevant TIS studies. In some instances, pipeline trip assignments may need to be assumed for the study area. A figure that summarizes pipeline project locations and pipeline project trip assignments is required with the TIS. A figure that highlights future baseline traffic volumes is also required.

- **Future Project Volumes.** Project trip generation, distribution, and assignment must also be summarized in the TIS, as specified by the TG&D section. Future with-project traffic volumes will be developed by combining project trip assignments with baseline traffic volumes. Figures that highlight project trip assignments and future with-project traffic volumes are required with the TIS.
- **Traffic Operations.** Traffic operations shall be gauged according to the intersection/driveway level of service (LOS) methodologies of the most current Highway Capacity Manual (HCM), as developed by the Transportation Research Board. A range of software options is acceptable for LOS calculations so long as methodologies are consistent with the HCM. LOS worksheets providing summary assumptions (channelization, controls, peak hour factors, heavy vehicle assumption, etc.) must be provided in the appendix to the TIS.

The LOS analysis will be provided for the existing, future baseline, and future with and without project conditions at site driveways and at study intersections. Note that LOS D is the threshold for traffic operations at signalized intersections, unsignalized intersections, and at project driveways within Bonner County; unless specified otherwise by the Road and Bridge Department.

- **Capacity Improvements.** As needed, improvements should be recommended to mitigate capacity issues within the study area (those intersections/driveways projected to operate below LOS D). It is expected that proposed transportation improvements operate effectively at LOS D or better for a period of 5 years. Forecasts and analyses confirming that said improvements would operate effectively for this timeline should be provided in the TIS. The estimated projects responsibility towards improvements should be provided based upon the general criteria summarized previously by this document. MUTCD (Manual on Uniform Traffic Control Devices) warrants should be utilized to support the need for 4-way stops and signals, as needed. AASHTO (American Association of State Highway and Transportation Officials, current edition) and/or ITD standards should be used to support the need for acceleration/deceleration lanes.
- **Queuing Analysis.** 95<sup>th</sup>-percentile queues should be summarized for existing and proposed intersection turn lanes based upon the future

project and improved/mitigated conditions. Per the discretion of the Road and Bridge Department, turn lanes would be extended, as necessary, to accommodate forecast traffic volumes with the development of the project. The project plus 5-year analysis is only required for those lanes or intersections that are proposed for improvement.

- **Additional Analysis (Discretionary).** The Road and Bridge Department may require additional analyses with the TIS that may include, but would not be limited to, weekday traffic forecasts, turn lane warrants, sight distance assessment, heavy vehicle characteristics (forecasts, operating times, turning pathways, etc.), special analysis conditions, pedestrian/bicycle facilities, air quality, noise, etc.
- **Summary and Conclusion.** The TIS must contain a summary section that clearly highlights the conclusions and recommendations of the study. This summary section should, if separated from the document for cursory review by members of the public or a public agency, would provide sufficient detail to convey a description of the project, provide a summary of trip generation and study results, and provide a clear understanding of proposed improvements and requirements/conditions of the project.

The attached spreadsheet summarizes the primary checklist that will be used for reviewing TIS reports. The spreadsheet also shows the preferred contents of a TIS; although, Bonner County is flexible so long as the required information is provided by the report.

**Bonner County Traffic Impact Study Checklist**

I. Introduction A. Study Purpose B. Project Location C. Project Description D. Scope of Work E. Methodologh and Assumptions	Clearly Defined			
	Yes	No	Location:	
			Action (Size):	
			Access:	
			Proposed Zoning:	
		Comments:		
II. Existing Conditions A. Roadway/Intersection Network B. Existing Volumes C. Existing LOS D. Collision Histories	Clearly Defined			
	Yes	No	LOS Issues:	
			Safety Issues:	
			Comments:	
III. Future Baseline Conditions A. Programmed Improvements B. Baseline Traffic Volumes C. Baseline Level of Service	Clearly Defined			
	Yes	No	Growth Rate:	
			Pipeline Projects:	
		LOS Issues:		
		Comments:		
IV. Future Project Conditions A. Project Trip Generation B. Trip Distribution and Assignment C. With-Project Volumes D. With-Project LOS E. Queues	Clearly Defined			
	Yes	No	Trip Generation:	
			Trip Distribution:	
			LOS Issues:	
			Project Impacts:	
		Queing Issues:		
		Comments:		
V. Improvements and Mitigation A. Improvement Options B. Project Contribution C. Project Longevity	Clearly Defined			
	Yes	No	Improvements:	
			Project Share:	
		Comments:		
VI. Summary and Conclusions (Project defined, trip generation, LOS Results, safety, improvements, mitigation)	Clearly Defined			
	Yes	No	Comments:	
VII. Other Study Issues: a. Lane Warrants B. Sight Distance C. Heavy Vehicles D. Pedestrian Facilities E. Signal Warrants	Clearly Defined		Figures:	Provided / Comments
	Yes	No	Site Plan	
			Site Location	
			Channelization	
			Existing Volumes	
		Pipeline Volumes		
		Baseline Volumes		
		Project Volumes		

General Study Comments:

PAGE INTENTIONALLY BLANK

## **SECTION 10: BONNER COUNTY GENERAL MAINTENANCE PROCEDURES**

The purpose of this section is to establish and compile into one place several maintenance procedures that Bonner County regularly performs. This section may be used as a guide to educate new employees, new commissioners, the public, etc, as to why and how the Road & Bridge department performs it's work.

Bonner County maintains over 700 miles of roads, of those, approximately 1/3 are hard surfaced as of the publication of this manual.

The section is organized as such:

- 10.1 General Maintenance Procedures
  - A. Traffic Counts
  - B. Winter Maintenance
  - C. Brushing
  - D. Weight Limits
  - E. Centerline Striping
- 10.2 Gravel Rd Specific Maintenance
  - A. Grading & Ditching
  - B. Magnesium Chloride Treatment
- 10.3 Hard Surface Rd Specific Maintenance
  - A. Crack Sealing & Pothole Patching
  - B. Chip Sealing
  - C. Hot Mix Asphalt Overlays
- 10.4 New Upgrades & Rebuilds
  - A. Cement Treated Base
  - B. BST – Bituminous Surface Treatment
  - C. New Asphalt
  - D. Local Improvement District

### **10.1 GENERAL MAINTENANCE PROCEDURES**

**A. TRAFFIC COUNTS** – Traffic counts are conducted periodically on roads to determine the level of use that they encounter. These counts are helpful in determining the level of maintenance and upgrades that are justified on a particular road.

Bonner County has 2 types of traffic counters; a radar unit over hard surfaced roads and a magnetic buried unit in gravel roads.

Counters are typically kept in place for a week to capture the entire spectrum of users, and usually done during the times of the year when the heaviest traffic is

expected.

**B. WINTER MAINTENANCE** – During the winter months, Road and Bridge plows snow and spreads sand on slippery road surfaces, curves, and hills as warranted. All three districts plow fleets will mobilize before normal start times when anticipated snowfalls are three to four inches. Priorities for the work are as follows:

1<sup>st</sup> Priority - School bus routes, arterials and major collectors.

2<sup>nd</sup> Priority - All other county maintained roads.

3<sup>rd</sup> Priority – Sanding.

Use of sand is limited to steep roadway grades such as in mountainous terrain, at intersections, on overhead structures, and in other areas determined by the department to be hazardous. It is not standard policy to sand straight stretches of roadway because of snow. Sand is not applied between 11pm - 4am due to no midnight crewman. Sand is not placed while snow is still falling, as it will just be covered up immediately. Road salt is not used in the sand.

Graders are also used to plow snow, and often come back through after the storm has passed to push back the berms and widen the road.

Bonner County requires space to turn a snow plow around at the end of the road. If such a turn-around is not available, Bonner County may cease winter plowing operations on that section of road until such time as an adequate turn-around is available.

Bonner County does not have the resources to place signs, flaggers, pilot trucks, etc, warning of snow plowing equipment operating out on the roads. It must be anticipated by the public that they may encounter snow plowing equipment during the winter months, and drive accordingly.

The County does not have the resources to clear driveways and private road intersections of snow once the plow passes. This is the responsibility of the homeowners. Residents who remove snow from their driveways are reminded that State law prohibits placing snow or ice on any public road in a manner that impedes vehicle and pedestrian traffic or makes it unsafe.

Mailboxes are occasionally damaged during snow removal operations. Replacement of damaged mailboxes due to snow being thrown from a plow is the responsibility of the property owner/resident per the Bonner County Road Standards Manual, Section 8.

**C. BRUSHING** – This policy and procedure has been adopted by Bonner County since 2013. It was developed to incorporate the maintenance guidelines set forth in the Federal Highways Department pamphlet titled *Vegetation Control*



*for Safety.* Roadside safety guidelines cannot be implemented on all Bonner County maintained roadways due to physical and topographic constraints, limited public rights-of-way, and limited budget allocations as set by the Bonner County Board of County Commissioners.

Roadside vegetation control shall be limited to those public roads that are in the County maintenance system, as approved by the Bonner County Board of Commissioners. Work should be limited to rights-of-way owned by Bonner County, dedicated public rights-of-way and prescriptive easements for public rights-of-way (as defined by Idaho law).

Operational Zone – It is the intention of Bonner County to maintain an operational zone about 10-feet to 12-feet wide beyond the edge of road shoulder for the enhancement of public safety. Width may be wider to match dedicated public rights-of-way. Width may be narrower where limited by rights-of-way and other physical constraints.

Primary goals of vegetation control are to provide the following:

1. Improved visibility of signs, pedestrians, livestock, and wildlife that may be along the roadside.
2. Improved visibility of oncoming vehicles near intersections, driveways, and around curves.
3. Reduce the number of trees near the roadway that could result in a severe accident if struck by a vehicle.
4. Provide an area for drivers to safely recover or stop in the event that a vehicle departs the travel lane.

This zone should be clear of trees with a diameter larger than 4-inches and brush taller than 3-feet. Tree limbs should be trimmed to a height of approximately 9-feet above the road shoulder and should not extend over the road travel lanes. Grasses are allowed and should be encouraged in order to choke out brush and provide erosion control.

“Common Sense” Exceptions: The Road and Bridge Director, or designated representative, should consider unique physical roadside circumstances to determine if tree removal from the operational zone may increase accident severity. Such determinations should be documented via memo and photographs. Said determination shall be retained in the file for that specific roadway. Examples of unique circumstances are listed, but not limited to the following:

1. Trees should be retained where said trees provide the only barrier to help prevent vehicles from plunging into water bodies of sufficient depth to partially or fully submerge a vehicle.

2. Trees should be retained where said trees provide the only barrier to help prevent vehicles from plunging more than 15-feet down an embankment with slope steeper than 2H:1V.
3. Trees on hillsides above the roadway may be left in place where steep slopes would most likely prevent vehicles from impacting said trees.
4. Trees should be retained where the removal may adversely affect embankment slope stability. Leaning or large trees may be removed from embankments to prevent slope failure should the naturally falling tree tear out its root wad. In the event that trees are cut from slopes, the root wad should remain to provide erosion control. Stumps should be cut as near to ground level as reasonably possible.
5. In all cases, trees within the operation zone may be removed where it is determined that other trees within or beyond the operational zone are reasonably expected to provide an adequate barrier.

#### Notice of Tree Trimming and Removal:

1. When tree trimming and/or removal work is scheduled, the Road and Bridge Director shall cause the edge of rights-of-way or limits of clearing to be marked by lathes with brightly colored ribbon on each affected road so as to reasonably give notice to the road users and property owners. Lathes and ribbon should be placed once every several hundred feet, or at parcel boundaries in a manner sufficiently close together to visually designate the limitations for vegetation control.
2. Trees located within the designated limits of clearing should be removed to enhance public safety. Trees with a 12-inch or larger diameter should be marked by a large white painted "X" facing the roadway, so as to reasonably give notice to the road user and property owners of pending tree removal.
3. When possible, prior to commencing tree trimming and removal work, Road and Bridge should place two or three large signs along the roadway noting pending vegetation removal. The signs, lathes with ribbons, and tree markings should be posted for approximately seven (7) calendar days before starting work. These postings shall serve as notice that vegetation control work is pending on a County maintained roadway.
4. Trees removed from rights-of-way owned by Bonner County are the property of Bonner County. Road and Bridge has the discretion, but not obligation, to either sell marketable timber, dispose of waste trees at an approved location, or may give trees to adjacent landowners upon request. Landowners will be responsible for all limbs and debris from trees left on their property at their request.
5. Trees cut down within prescriptive easements for public rights-of-way (as defined by Idaho law) are the property of the landowner. Road and Bridge staff should make a reasonable effort to receive landowner's written instruction to:
  - a) leave fallen trees on the parcel and outside of the operational zone,

including leaving limbs and debris, or  
b) have Road and Bridge haul away the trees, including limbs and debris.

Reasonable effort to contact excludes mass mailing to landowners. Landowners will be responsible for all limbs and debris from trees left on their property at their request. When the landowners provide written permission to Bonner County to haul marketable timber, the proceeds go to the County. If a landowner cannot be contacted by reasonable means, then trees and limbs should be hauled away to reduce fire hazard.

Application of Herbicide – Control of brushy vegetation along with noxious weeds by the application of herbicides is the most cost effective maintenance strategy for County maintained roadways. Application is typically conducted in one of the three maintenance districts annually, creating a once every three year application cycle. Spray should be limited to within 10-feet of the road shoulder and conducted in a manner to minimize spray drift as much as possible. All manufacturer instructions and regulatory guidelines should be followed. Those not wanting the right-of-ways adjacent to their property sprayed should obtain a

No Spray Agreement application from the Noxious Weed Control Department. These forms and signs are free, and must be posted by the owner at the property corners. Property owners are responsible for the eradication of noxious weeds in those areas. We cannot honor signs that are not obtained from the County and particularly without a signed agreement. If weed control has not happened on or before July 15<sup>th</sup>, the marked No Spray area may be sprayed for weed infestations.

Roadside Mowing – Grass and brush height may be controlled by the use of power mowing equipment on County maintained roadways. Mowing is typically conducted annually by Road and Bridge staff. The effective width of the mower may be 2-feet to 6-feet wide from the shoulder of the road depending on terrain. Public notification of pending mowing operations is not practical.

**D. WEIGHT LIMITS & FROST LAW** – Weight limits were established by the Board of County Commissioners Under Bonner County Revised Code Title 2 Chapter 3 – “Frost Law, Weight & Hauling Limits.” This ordinance is available on the Bonner County website on the Road & Bridge Dept tab, or at [http://sterlingcodifiers.com/codebook/index.php?book\\_id=827](http://sterlingcodifiers.com/codebook/index.php?book_id=827). In all cases, the ordinance shall govern over the supplemental information contained in this section of the manual.

Bonner County roads are in a region that experiences a freeze-thaw environment. Frost action can create several damaging effects to roads with frost heaves and failure of the road base to support heavy loads during periods of thawing. During thawing periods, heavy tire loads can damage the road in the form of rutting, “mud boils” coming up in spots, cracking pavement, etc.

Extended freezes and traffic can drive the frost depth below 2ft or more. During periods of warmer weather, the roads begin to thaw from the top down and also from the bottom up. It can be difficult to predict when the dates for spring thaw will begin and for how long weight limits should be in place. However, the most critical time for placing the spring road restrictions appears to be when the surface structure has thawed to a depth of 3-6 inches, and lasting until the road is completely thawed.

Protecting the local roads from damage by heavy vehicles is the responsibility of Bonner County. In establishing weight limits to extend the life of the roads, Bonner County must incorporate judgement to balance the need for protecting roads while maintaining commerce and an efficient transportation system. Bonner County relies on local experience, air temperature data, and frost probes to monitor the conditions and determine when weight limits are in effect.

Ordinance 422 does provide exceptions for some critical services such as emergency services and school busses, as well as allowing some essential haulers (heating oil, septic pumping, garbage trucks, etc) to haul half loads.

**E. CENTERLINE STRIPING** – Centerline striping can be used to delineate the travel lanes and provide or disallow passing zones. Centerline striping can improve safety by keeping traffic on the correct side of the road and making the road easier to follow at night.

Bonner County attempts to place centerline striping on most roads which are 45mph or higher, especially if they are curvy and/or heavily traveled. On roads which have a combination of 45mph and 35mph, the entire length may be striped where appropriate. Stripes are typically painted every other year on a given road, with half of the roads being done each year. Budget allowances will often be a determining factor in striping, and these striping goals may not always be possible to meet.

When a road is chip sealed and the stripe is completely covered up, the stripe may not be re-applied until the following year to allow chip loss to occur before striping.

The following table is from Section 6, and also placed here for convenience.

**Table 5: Stopping and Passing Sight Distance Requirements**

Design Speed (MPH)	25	35	45	55
Stopping Sight Distance (Feet)	155	250	360	495
Minimum Required Sight Distance to Start a Passing Zone (Feet)	940	1040	1458	1918
Minimum Sight Distance Remaining to End Passing Zone (MUTCD Table 3B-1) (Feet)	450	550	700	900

## **10.2 GRAVEL ROAD SPECIFIC MAINTENANCE**

**A. GRADING & DITCHING** – Bonner County operates road graders on gravel roads to mold and shape the road, smooth the surface, eliminate washboards and potholes, and to re-establish ditches.

Grading work can only be effectively accomplished when there is an appropriate amount of moisture in the gravel material. As a result, the majority of the grading work that Bonner County does occurs in the spring and fall in the days following rainstorms.

Heavily traveled roads may develop washboards and potholes in dry years, requiring patience from all road users until the rains return.

Gravel roads are typically graded with a 4% crown in the middle (vs 2% typical on paved roads). This steeper road crown helps move water off the road and prevents potholes.

Bonner County will occasionally re-establish ditches with the grader. Pulling the organic material in the ditches and mixing it with the road can actually improve the road surface, as the organic materials help bind the gravel material together and help prevent washboarding.

**B. MAGNESIUM CHLORIDE ROAD STABILIZATION** – Bonner County applies magnesium chloride (“MagCl”), a salt brine liquid, onto heavily traveled gravel roads. The primary goal of the treatment is to retain the gravel materials and extend the time between required gravel rebuilds. Dust control is a secondary benefit of the program. MagCl is corrosive to vehicles, but is water soluble and can be washed off with water.

Bonner County considers applying MagCl to roads which have traffic counts over 100 cars per day (ADT = Average Daily Traffic) in the spring. It has been determined that this is the break-even point where the cost of the MagCl is equivalent to the cost of replacing the lost gravel and increased maintenance required on roads which are not treated.

Less than 100 ADT – No treatment.

100-200 ADT – Treated with MagCl

200-300 ADT – Treated with 2 shots of MagCl, when budget allows.

300+ ADT – Treated with 3 shots of MagCl, when budget allows.

Residents who live on roads which do not receive treatment may hire a contractor to place MagCl or other approved treatments (oil is not allowed) in front of their homes at their own expense. Visit the Road and Bridge office to

obtain an encroachment permit and set this up. Road and Bridge crews will attempt to coordinate with the contractor to grade the road just before treatment is applied so that it is shaped properly before setting up, when crews are available. Ordinance 409 (Recorded as Instrument # 582507) contains additional info on specific requirements of the permit for application of dust abatement by private parties, including insurance, materials, restrictions, etc.

More information is available in Bonner County Revised Code Title 2 Chapter 4 – “Bonner County Dust Abatement Policy.” This is viewable at:  
[http://www.sterlingcodifiers.com/codebook/index.php?book\\_id=827&chapter\\_id=58198#s1038344](http://www.sterlingcodifiers.com/codebook/index.php?book_id=827&chapter_id=58198#s1038344)

### **10.3 HARD SURFACE (ASPHALT, BST) ROAD SPECIFIC MAINTENANCE**

**A. CRACK SEALING AND POT HOLE PATCHING** – In order to keep water out of the road and subsurface and extend the life of the road, cracks are routinely filled by Bonner County with an oil based product. If a pothole does occur, Bonner County will attempt to patch it using a Durapatcher machine, which uses a mixture of tacky oil and rock to fill the hole. This is typically an effective permanent fix. In the winter months, it is too cold for the Durapatcher to operate, and so crews will temporarily fill holes with cold mix asphalt product which can last until spring.

**B. CHIP SEALING** – Chip seals are accomplished by spraying an oil emulsion (CMS-2P) on the surface of the road, and then spreading 3/8” rock chips on top of that. In order to keep water out of the road and subsurface and extend the life of the road, chips seals are routinely done by Bonner County to create a new impervious seal on top of all hard surfaced roads.

Bonner County attempts to chip seal all hard surfaced roads every 5 to 7 years, as budget allows and road conditions warrant.

Chip seals are assumed to add 5 years to the remaining service life (RSL) of a road.

**C. HOT MIX ASPHALT OVERLAYS** - A hot mix asphalt (HMA) overlay is typically 1.5 to 2.5 inches thick. The product is the same as would be used on a new asphalt road, just placed in a thinner mat. Using a tack oil first to bind the old and new asphalt together, the overlay is placed directly on top of the existing road surface.

It has been and will continue to be the focus of Bonner County to preserve the arterials and collectors as the highest priority for road maintenance funding. Local access roads will be secondary in priority to receive HMA overlays, rebuilds, etc.

## **10.4 NEW UPGRADES & REBUILDS**

**A. CEMENT TREATED BASE** – For roads which are being completely rebuilt, it may be cost effective to perform a cement treated base in areas with poor soil conditions. During this process, Bonner County grinds and pulverizes the existing road to a depth of 10”, and then mixes dry cement powder and water into the ground-up road base and allows it to cure for a week.

Either geotextile fabric or a new 4” layer of gravel can be placed on top of the CTB, and then new hot mix asphalt paved over the top to create a reconstructed road with improved base strength.

**B. BST – BITUMINOUS SURFACE TREATMENT** – One option for converting a gravel road to a hard surfaced road is BST, which can be a cost effective alternative to new asphalt in certain scenarios. The cost is less than half that of new asphalt (\$75,000/mile (BST) vs \$225,000/mile (asphalt) as of 2017).

Below is a list of some factors which should be considered when looking at BST:

1. BST is thin and flexible and does not provide strength like asphalt. As a result, it should only be used on roads which have a quality gravel base section which is well drained to provide the required strength.
2. BST does not work well for roads which experience heavy truck traffic, because of its lack of strength. Especially if trucks will be making sharp turns on the BST, which tends to displace the rock from the oil.
3. BST does not provide as smooth of a driving surface as asphalt, giving more bumps and humps which would not be as well suited for high speeds.
4. BST has a shorter lifespan than asphalt, especially on roads with heavy traffic volumes. The lifespan varies significantly based on these factors.
5. BST is more susceptible to damage from equipment like track hoes operating on the road, or snow plow blades.
6. BST is not as well suited for exceptionally shaded areas, as the heat from the sun is necessary in curing the oil and binding the layers together.

Bonner County will typically not consider placing BST on a road unless it has at least 250 ADT. If the road has more than 500 ADT, asphalt would be a more appropriate option. While there are numerous gravel roads throughout the county that have over 250 ADT, the budget often does not allow for new BST surfacing to be placed. Maintaining the existing hard surface roads takes priority over creating new hard surfaced roads.

**C. NEW ASPHALT** – Bonner County may consider placing new asphalt on a road with at least 500 ADT. It may also be necessary in some cases to consider the average traffic counts between peak and off-peak seasons when considering roads for new asphalt. While there may be numerous gravel roads throughout the county that have over 500 ADT, the available budget often does not allow for

new asphalt surfacing to be placed. While new pavement on gravel roads is popular with the public, if it causes delays in needed maintenance on other existing hard surfaced roads and bridges, the costs of delayed work increases exponentially in the following years. As a result, maintaining the existing network will take priority over new asphalt. In some cases, Bonner County may receive a grant to pave new HMA on a road which is less than 500 ADT.

When placing new asphalt (or BST), Bonner County should evaluate culverts and replace any that show signs of age before paving. The ditches should also be re-established and improved where possible. In many cases, new gravel should be placed prior to paving, and the road should be graded to give 2% crown on straight sections and superelevation through the curves instead of a typical 4% gravel road crown the entire length.

New asphalt is typically placed in two lifts, at 3.5" to 4" depth.

**D. LOCALLY FUNDED IMPROVEMENTS** – Residents who desire improvements to their local road may consider a Locally Funded Improvement (LFI) to assist in the funding of a project. LFI's shall be voluntary, with no requirement for unwilling residents to participate financially. Interested residents may approach the Director and/or the Board of County Commissioners to request a LFI. If Bonner County deems the project worthy of public participation, they may enter into a written agreement with a legally formed organization (i.e. an LLC) representing the residents to establish the purpose, cost estimate, funding mechanisms, delegation of responsibilities, etc.

The Locally Funded Improvements are separate and distinct from the Idaho state statutes governing Local Improvement Districts (LID's), which are often compulsory. Residents interested in forming an LID may still do so, in accordance with state statutes.

Under no circumstances will Bonner County be required to participate in a LFI, and may refuse to allow the project on public right-of-way. Consideration of whether other projects are higher priorities for use of County funds will be a part of that decision, as well as whether or not Bonner County has the funds available to participate. An agreement should clearly state that while the project is being initially privately funded, the LFI project, the road, and other appurtenant items in the right-of-way belong to Bonner County, and all future maintenance, utilities, encroachments, projects, etc are under the sole discretion of Bonner County.

Residents shall fund the materials costs and any required contractor costs for a LFI or a portion of said costs in accordance with the following table at the discretion of the Board of County Commissioners, with the possibility of Bonner County participating with the remainder of materials costs, engineering, project management, labor, and County equipment as deemed appropriate. The Board of County Commissioners may consider unique circumstances which might



change the required match amounts. For example, if more than 25% of the abutting property along the length of the road is publicly owned, the required privately funded percentage may drop by up to an additional 10% from what is shown in the table.

Estimated Material & Contractor Costs	Percent to be Privately Funded
\$0-50,000	100%
\$50,001 - \$100,000	90%+
\$100,001 - \$150,000	80%+
\$150,001 - \$200,000	70%+
\$200,001 +	60%+

Residents must place the money for the project into escrow or other approved holding account before any work begins to ensure that the project is properly funded in advance.

Example scenario: Many residents living on Bumpy Road want their road paved. The road is currently 18ft wide and gravel, and 1 mile long. 50 residents live on the road. During a neighborhood meeting, 22 of the 50 residents feel they are interested in helping to finance the paving of the road, and sign a petition that they bring to a meeting they schedule with Bonner County to discuss the possibility and the costs. Bonner County is interested in the project, and the Road and Bridge Dept establishes a initial cost estimate to widen the road to 22ft and pave it with 3.5" of asphalt.

The materials, asphalt, and chip sealing costs (including contractor work to lay the asphalt) amount to \$287,000 in the initial estimate. This cost is presented to the interested residents, who have another neighborhood meeting to discuss if the 22 interested residents can raise the required \$172,200 (60% of \$287,000). Several residents can only spare \$3000 towards the project, but others feel they can contribute significantly more than their fair share to move the project forward.

In the end, they have enough interested residents that have verbally committed that they believe they can raise the required \$172,200 for their portion of materials & contractor costs. They form a legal LLC and return to Bonner County to write up a formal agreement to create the LFI. The LLC and Bonner County sign the agreement which details funding obligations, and the residents place their money into an escrow account. Bonner County begins project design and engineering, and then County crews begin purchasing gravel on the open market to use on the road, hauling it, placing it, compacting it, etc. The road base is widened to 24ft using \$50,000 worth of gravel.

Bonner County obtains 3 bids for contractors to place asphalt, and signs a contract with the low bidder, Budget Paving Inc. for the amount of \$190,000. Budget Paving Inc. comes in and paves 3.5" of asphalt the following month.

Bonner County comes back with another \$5,000 worth of gravel to finish the shouldering and driveway transitions. A week later, Bonner County spends another \$30,000 on chip seal oil and \$3400 on chips and performs a chip seal to protect the surface of the road and provide a quality traction surface. In the end, total material and contractor costs are:

$\$50,000 + \$190,000 + \$5,000 + \$30,000 + \$3,400 = \$278,400.$

The savings from actual costs being lower than estimated costs will go towards Bonner County's portion of the match. The full \$172,200 is transferred from escrow to Bonner County. 7 years later, Bonner County performs another chip seal, entirely at Bonner County's expense.

50 years later, the asphalt is in failing condition despite regular chip seals, and Bonner County is not interested in overlaying or rebuilding the road because the traffic counts do not justify such an expense of public dollars. There is discussion of grinding the road up and returning it to gravel. Once again, the residents on the road band together to raise \$125,000 for another LFI to overlay the road with 1.5" of asphalt and prevent it from being returned to gravel, and the process begins again.

**APPENDIX A:  
ADOPTING ORDINANCE & RESOLUTION**

ORDINANCE NO   472  

**BONNER COUNTY ROAD SPECIFICATIONS**

AN ORDINANCE OF BONNER COUNTY, IDAHO SETTING FORTH ITS AUTHORITY; AMENDING TITLE 2, CHAPTER 8, SECTION 810 BY PROVIDING FOR AMENDING AND ADOPTION OF THE ROAD STANDARDS MANUAL DATED DECEMBER 2005 VERSION I; ALLOWING FURTHER AMENDMENTS TO THE ROAD STANDARDS MANUAL TO BE AMENDED BY RESOLUTION; ESTABLISHING THE SETTING AND COLLECTION OF FEES BY RESOLUTION; REPEALING TITLE 2, CHAPTER 8, SECTION 810 (D) IN ITS ENTIRETY; AMENDING TITLE 2, CHAPTER 8 SECTION 2-890 PROVIDING FOR PENALTIES AND REMEDIES; ESTABLISHING TITLE 2, CHAPTER 8, SECTION 2-900 PROVIDING FOR THE ISSUANCE OF STOP WORK ORDERS; PROVIDING FOR SEVERABILITY; PROVIDING FOR CODIFICATION OF THE ORDINANCE; AND PROVIDING FOR AN EFFECTIVE DATE.

**WHEREAS**, The Bonner County Commissioners have adopted standards identified in Title 2 Chapter 8 of the Bonner County Revised Code consistent with their power established under Title 31 and Title 40 of Idaho code; and

**WHEREAS**, the Bonner County Commissioners desire to amend certain standards, or adopt revised standard for the purpose of clarification and bringing uniformity of certain sections of Title 2, Chapter 8 of Bonner County Revised Code; and

**WHEREAS**, Bonner County pursuant to law, adopted Ordinance 236, 1/29/94 and Ordinance 269, 1/17/1995 and Ordinance 280, 4/5/1995 and Ordinance 368, 1/14/1999 and Ordinance 422, 3/5/2002 and Ordinance 426, 6/18/2002 and;

**WHEREAS**, the Board of Bonner County Commissioners desire to allow further amendments to the Road Standards Manual to be amended by resolution and;

**WHEREAS**, the Board of Bonner County Commissioners desire to set fees to be collected by the Bonner County Road and Bridge Department by resolution and;

**WHEREAS**, the Board of Bonner County Commissioners did hold a public meeting on December 27, 2005 and;

**NOW, THEREFORE BE IT ORDAINED** by the Board of Bonner County Commissioners of Bonner County, Idaho, that the following be and is hereby adopted as an ordinance of Bonner County:

**SECTION I: AUTHORITY**

This ordinance is adopted pursuant to the authority granted at Idaho Code Title 31 and Title 40.

**SECTION II:** Amending Title 2, Chapter 8, Section 810(a) to read as follows: The Road Standards Manual dated December 2005 Version I is hereby adopted and incorporated herein as if set forth is full. All new construction of roads built for dedication to Bonner County and construction within County rights of way for which standards are set forth shall comply with the standards contained within the manual. As a part of the decision to permit roads and construction encroachments within the County rights of way the Public Works Department may enter into development agreements with the encroachment

applicants that may require the completion of improvements to mitigate the increase in traffic as a result of the project development or encroachment. Alternately, the Public Works Department may allow an applicant to participate proportionately with other applicant and /or other public entities to construct improvements that are not exclusively the responsibility of any single applicant or entity. Development agreements shall be approved by the Bonner County Board of Commissioners by resolution.

Section 2-810 (d) is hereby amended to read as follows: Amendments to the Road Standards Manual shall hereafter be made by resolution of the Bonner County board of Commissioners.

Section 2-890 is hereby amended to read as follows: 2-890, **Penalties and remedies.**

(a) It shall be unlawful for any person, firm or corporation to do, cause, or permit to be done, whether acting as principal, agent or employee, any construction, placement, installation, enlargement, extension, or structure subject to the provisions of this title which is not in accord with an approved permit issued under the terms of this title or without first procuring a permit from the Bonner County Public Works department.

(b) Violations of any provision of this title, or failure to comply with any of the requirements of this title, shall be a misdemeanor and shall be punishable by imprisonment in a county jail not exceeding six (6) months, or by a fine not exceeding three hundred dollars (\$300.00), or by both.

(c) A separate violation shall be deemed to have occurred for each construction, placement, installation, enlargement, extension, or structure subject to the provisions of this title that is erected, constructed, placed, installed, enlarged, extended, moved or converted not in compliance with this title. Each day such violation continues constitutes a separate offense.

(d) The prosecuting attorney may take whatever criminal action deemed necessary to enjoin any violation of this title. The prosecuting attorney may, with the consent of the county commissioners, bring whatever civil action deemed necessary to enjoin any violation of this title. Civil remedies may be sought in addition to, or in lieu of, criminal penalties.

(e) Any person, whether acting as principal, agent, employee, landowner, tenant, builder, or any other person who commits, participates in, assists in or maintains such violation, may be found guilty of a separate offense. Nothing herein contained shall prevent the Bonner County prosecuting attorney and/or the Bonner County commissioners, or any other public official or private citizen, from taking such lawful action as is necessary to restrain or prevent any violation of this title.

(f) Fee for investigation of work without permit. Whenever any work for which a permit is required under the terms of this title has commenced without first obtaining said permit, an investigation fee shall be collected whether or not a permit is then or subsequently issued. The payment of the investigation fee shall not exempt any person from compliance with all other provisions of this title nor from any penalty prescribed by law. A separate investigative fee shall be charged for each site visit to the subject property conducted by the Bonner County Public Works Department.

Establishing Section 2-900 allowing for the issuance of stop work orders;**2-900, Issuance of stop work order, unlawful continuance.**

(a) Whenever the public works director finds any work regulated by this title being performed in a manner contrary to the provisions of this title, the public works director or his or her designee is authorized to issue a stop work order.

(b) The stop work order shall be in writing and shall be posted on the premises where the work is being conducted or given to the owner of the property involved, or to the owner's agent, or to the person or persons performing the work. Written notice shall also be provided by the public works department by certified mail to the landowner at the address shown on the county assessor's tax rolls. Upon issuance of a stop work order, the cited work shall immediately cease. The stop work

order shall state the reason for the order, and the conditions under which the cited work will be permitted to resume.

**SECTION III:** The setting of fees, to be collected by the Bonner County Public Works Road and Bridge Department, shall hereby be set by resolution of the Board of Bonner County Commissioners.

**SECTION IV: SEVERABILITY**

The provisions of this Ordinance are hereby declared individually severable. Should any provisions of this Ordinance be declared invalid by a Court of competent jurisdiction, such declaration shall not affect the validity of the remaining provisions.

**SECTION V: CODIFICATION OF ORDINANCE**

This ordinance shall be codified as a part of the Bonner County Revised Code.

**SECTION VI: EFFECTIVE DATE**

This Ordinance shall be in full force and effect upon its passage and publication in one (1) issue of the Bonner County Daily Bee newspaper.

**APPROVED AND ADOPTED THIS** 10<sup>th</sup> day of January, 2006, upon the following roll call vote:

Chairman Phillips:

Yes                      No

Commissioner Young:

Yes                      No

Commissioner Dye:

Yes                      No

---

Marcia L. Phillips, Chairman

---

Joseph E. Young, Commissioner

---

Karl J. Dye, Commissioner

---

ATTEST: Marie Scott, Clerk

By Becky Witte, Deputy Clerk

**RESOLUTION NO. 19-36**

**AMENDED BONNER COUNTY ROAD STANDARDS**

**WHEREAS**, The Bonner County Commissioners have adopted standards and fees identified in Title 2 Chapter 8 of the Bonner County Revised Code consistent with their power established under Title 31 and Title 40 of Idaho code; and

**WHEREAS**, the Bonner County Commissioners desire to amend and update certain standards within the Bonner County Roads Standards Manual (BCRSM) which have been in effect since 2017, and;

**WHEREAS**, Bonner County pursuant to law, adopted Ordinance 236, 1/29/94 and Ordinance 269, 1/17/1995 and Ordinance 280, 4/5/1995 and Ordinance 368, 1/14/1999 and Ordinance 422, 3/5/2002 and Ordinance 426, 6/18/2002 and Ordinance 472, 1/10/2006 and can make future changes via resolution and;

**NOW, THEREFORE BE IT ORDAINED** by the Board of Bonner County Commissioners of Bonner County, Idaho, that the following be and is hereby adopted as an amendment to ordinance #472 of Bonner County:

ROADS STANDARDS MANUAL VERSION II shall be updated to ROADS STANDARDS MANUAL VERSION 2.1 with changes to Section 10.4.D-Locally Funded Improvements, as presented by the Road and Bridge Department.

**APPROVED AND ADOPTED THIS** 12th day of March, 2019,

  
\_\_\_\_\_  
Jeff Connolly, Chairman

  
\_\_\_\_\_  
Dan McDonald, Commissioner

  
\_\_\_\_\_  
Steven Bradshaw, Commissioner

  
\_\_\_\_\_  
ATTEST: Deputy Clerk

**RESOLUTION NO. 17-133**

**AMENDED BONNER COUNTY ROAD STANDARDS**

**WHEREAS**, The Bonner County Commissioners have adopted standards and fees identified in Title 2 Chapter 8 of the Bonner County Revised Code consistent with their power established under Title 31 and Title 40 of Idaho code; and

**WHEREAS**, the Bonner County Commissioners desire to amend and update certain roads standards which have been in effect since 2006 to address current needs, correct deficiencies, provide numerous clarifications, and establish separate requirements for privately maintained public roads; and

**WHEREAS**, Bonner County pursuant to law, adopted Ordinance 236, 1/29/94 and Ordinance 269, 1/17/1995 and Ordinance 280, 4/5/1995 and Ordinance 368, 1/14/1999 and Ordinance 422, 3/5/2002 and Ordinance 426, 6/18/2002 and Ordinance 472, 1/10/2006 and can make future changes via resolution and;

**NOW, THEREFORE BE IT ORDAINED** by the Board of Bonner County Commissioners of Bonner County, Idaho, that the following be and is hereby adopted as an amendment to ordinance #472 of Bonner County:

ROADS STANDARDS MANUAL VERSION I shall be updated to ROADS STANDARDS MANUAL VERSION II as presented by the Road and Bridge Department.

**APPROVED AND ADOPTED THIS** 5th day of December, 2017,

  
\_\_\_\_\_  
Glen Bailey, Chairman

  
\_\_\_\_\_  
Dan McDonald, Commissioner

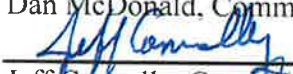
  
\_\_\_\_\_  
Jeff Connolly, Commissioner

  
\_\_\_\_\_  
ATTEST: Deputy Clerk



## **APPENDIX B: FEE SCHEDULE**











## **BONNER COUNTY ROAD & BRIDGE**

2019

Director: Steve Klatt  
Engineer: Matt Mulder, PE  
Senior Secretary: Lisa Saldana  
Administrative Assistant: Debbie Allen  
Sign Technician: Rowdy McDonald

District 1 Foreman:  
Jason Topp  
District 1 Asst. Foreman:  
Brian Reynolds

District 2 Foreman:  
Dan Brower  
District 2 Asst. Foremen:  
Mike O'Brien & Mark Reed

District 3 Foreman:  
Tom Klopman  
District 3 Asst. Foreman:  
Pete Hughes

District 1 Commissioner:  
Stephen Bradshaw

District 2 Commissioner:  
Jeff Connolly

District 3 Commissioner:  
Dan McDonald